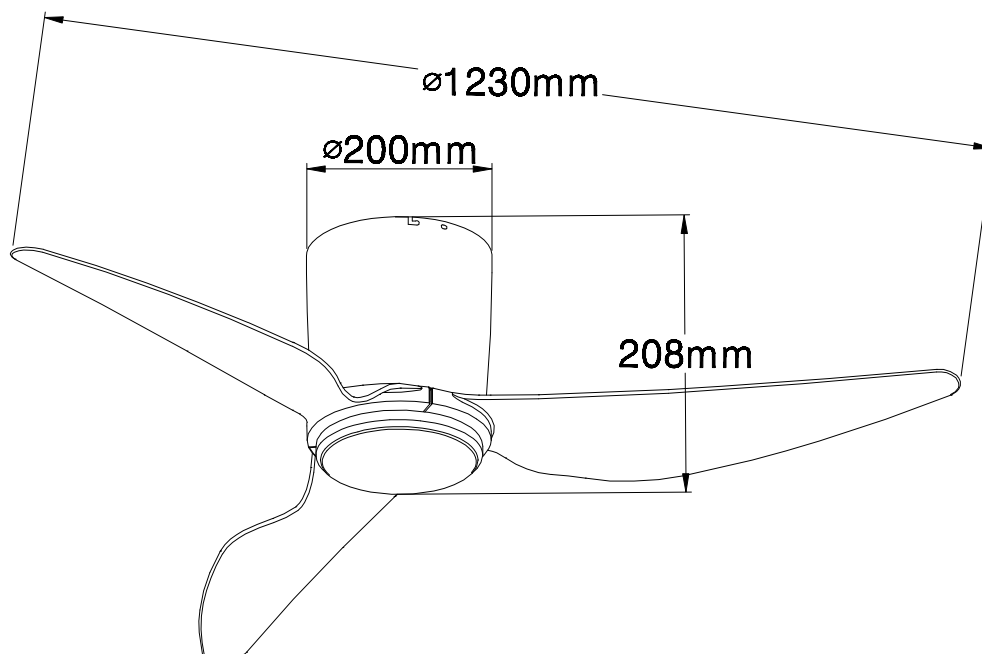

**10022117**Motor: 40 Watt  
220-240V ~ 50Hz**(DE) Bestimmungsgemäße Verwendung**

**(EN) Intended use | (FR) Utilisation conforme | (NL) Beoogd gebruik | (PL) Stosowanie zgodnie z przeznaczeniem | (NO) Riktig bruk | (DK) Korrekt brug  
(SE) Avsedd användning | (FI) Määräystenmukainen käyttö | (IT) Impiego appropriato | (ES) Uso prescrito | (CZ) Použití v souladu s určením  
(PT) Utilização correta | (GR) Ενδειγμένη χρήση | (SK) Predpokladané použitie | (EE) Eeldatav kasutus | (LV) Paredzamais lietojums  
(LT) Numatomas naudojimas | (RO) Utilizare intenționată | (SI) Predvidena uporaba | (HR) Namjenska upotreba | (HU) Tervezett felhasználás  
(BG) предназначена употреба | (AL) Përdorimi i parashikuar | (MK) Предвидена употреба | (TR) Amaçlı kullanım | (UK) Призначене використання  
(BA,ME,RS) Namjenska upotreba**

<b>(DE)</b> Ortsfeste Verwendung als Deckenventilator im Innenbereich	<b>(GB)</b> Provided for stationary use as ceiling fan, indoors
<b>(FR)</b> Prévu pour une utilisation stationnaire comme ventilateur de plafond, à l'intérieur	<b>(NL)</b> Voorzien voor stationair gebruik als plafondventilator, binnenshuis
<b>(PL)</b> Przeznaczony do użytku stacjonarnego jako wentylator sufitowy, wewnątrz pomieszczeń	<b>(NO)</b> Leveres for stasjonær bruk som takvifte, innendørs
<b>(DK)</b> Forudsat til stationær brug som loftsventilator, indendørs	<b>(SE)</b> Avsedd för stationär användning som takfläkt, inomhus
<b>(FI)</b> tarkoitettu käytettäväksi kiinteästi kattotuulettimena sisätiloissa	<b>(IT)</b> Fornito per l'uso stazionario come ventilatore a soffitto, in ambienti interni
<b>(ES)</b> Se suministra para uso estacionario como ventilador de techo, en interiores	<b>(CZ)</b> Pro stacionární použití jako stropní ventilátor, v interiéru
<b>(PT)</b> Fornecido para uso estacionário como ventilador de tecto, dentro de casa	<b>(GR)</b> Προβλέπεται για σταθερή χρήση ως ανεμιστήρας οροφής, σε εσωτερικούς χώρους
<b>(SK)</b> Pevné použitie ako stropný ventilátor v interiéri	<b>(BG)</b> Стационарна употреба като таванен ventilator за вътрешна употреба
<b>(EE)</b> Stacionaarne kasutamise laeventilaatorina siseruumides	<b>(LV)</b> Fiksēta lietošana kā griestu ventilators iekštelpās
<b>(LT)</b> Fiksuotas naudojimas kaip lubų ventiliatorius patalpose	<b>(RO)</b> Utilizare fixă ca ventilator de tavan în interior
<b>(SI)</b> Fiksna uporaba kot stropni ventilator v notranjih prostorih	<b>(HR)</b> Fiksna upotreba kao stropni ventilator u unutrašnjosti
<b>(HU)</b> Helyhez kötött használat mennyezeti ventilátorként beltérben	<b>(AL)</b> Përdorim i palëvizshëm si ventilator taveni në ambiente të brendshme
<b>(MK)</b> Фиксна употреба како тавански ventilator во внатрешноста	<b>(TR)</b> İç mekanda tavan vantilatörü olarak sabit kullanım
<b>(UK)</b> Стационарне використання як стельовий вентилятор у приміщенні	<b>(BA)</b> Fiksna upotreba kao stropni ventilator u unutrašnjosti
	<b>(ME)</b>
	<b>(RS)</b>

(DE) Lieferumfang		
(EN) Package contents   (FR) Contenu de la livraison   (NL) Bij de levering inbegrepen   (PL) Zakres dostawy   (NO) Levering   (DK) Leveringsomfang (SE) Leveransomfattning   (FI) Toimitussisältö   (IT) Fornitura   (ES) Volumen de suministro   (CZ) Rozsah dodávky   (PT) Material fornecido (GR) Παραδοτέος εξοπλισμός   (SK) Obsah balenia   (EE) Pakendi sisu   (LV) Pakas saturs   (LT) Pakuotės turinys (RO) Conținutul pachetului   (SI) Vsebina paketa   (HR) Sadržaj paketa   (HU) A csomag tartalma   (BG) обхват на доставката (AL) Përmbajtja e dorëzimit   (MK) Содржина на испорака   (TR) Teslimat içeriği   (UK) Зміст доставки   (BA,ME,RS) Sadržaj isporuke		
(DE) 1 Deckenventilator Montagematerial Montageanleitung	(GB) 1 ceiling fan Installation hardware Mounting instructions	(FR) 1 Ventilateur de plafond Matériel de montage Instructions de montage
(NL) 1 Plafondventilator Monteringsmateriale Montagehandleiding	(PL) 1 Wentylator sufitowy Elementy montażowe Instrukcja montażu	(NO) 1 Takviften Monteringsmateriale Brukerveiledning
(DK) 1 Loftventilator Monteringsmateriale Brugervejledning	(SE) 1 Takfläkt Monteringsmaterial Monteringsanvisning	(FI) 1 Kattotuuletin Asennusmateriaali Asennusohjeet
(IT) 1 Ventilatore da soffitto Materiale di montaggio Istruzioni di montaggio	(ES) 1 Ventilador de techo Material de montaje Instrucciones de montaje	(CZ) 1 Stropní ventilátor Materiál pro montáž Návod k montáži
(PT) 1 Ventilador de teto Material de montagem Instruções de montagem	(GR) 1 Ανεμιστήρας οροφής Υλικά συναρμολόγησης Οδηγίες συναρμολόγησης	(SK) 1 stropný ventilátor Inštalačný hardvér Inštalačná príručka
(BG) 1 таванен вентилатор материали за монтаж инструкции за монтаж	(EE) 1 laeventilaator Paigaldustarvikud Paigaldusjuhend	(LV) 1 griestu ventilators Instalācijas aparatūra Uzstādīšanas instrukcija
(LT) 1 lubų ventiliatorius Montavimo aparatinė įranga Montavimo instrukcija	(RO) 1 ventilator de tavan Hardware de instalare Instrucțiuni de montare	(SI) 1 stropni ventilator Namestitvena strojna oprema Navodila za montažo
(HR) 1 stropni ventilator Instalacijski hardver Upute za montažu	(HU) 1 mennyezeti ventilátor Telepítési hardver Szereelési útmutató	(AL) 1 ventilator tavani Materiali i montimit Udhëzuesi i montimit
(MK) 1 тавански вентилатор Монтажен материјал Упатство за монтажа	(TR) 1 tavan vantilatörü Montaj malzemesi Montaj kılavuzu	(UK) 1 стельовий вентилятор Монтажний матеріал Інструкція з монтажу
(BA) 1 stropni ventilator (ME) Montažni materijal (RS) Uputstvo za montažu		

The fan is to be installed so that the blades are more than 2,3 m above the floor.

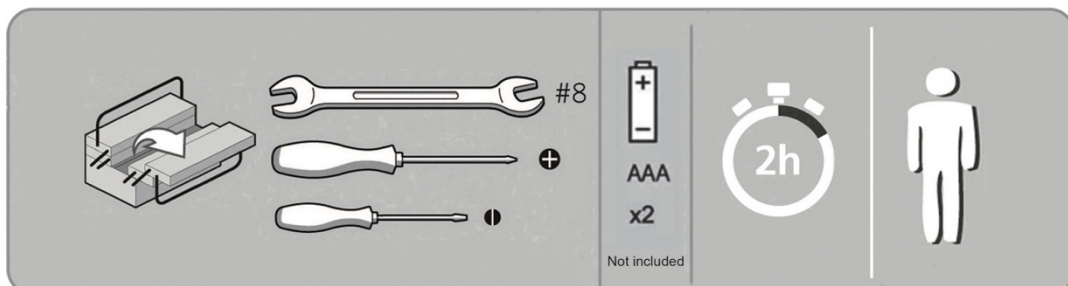
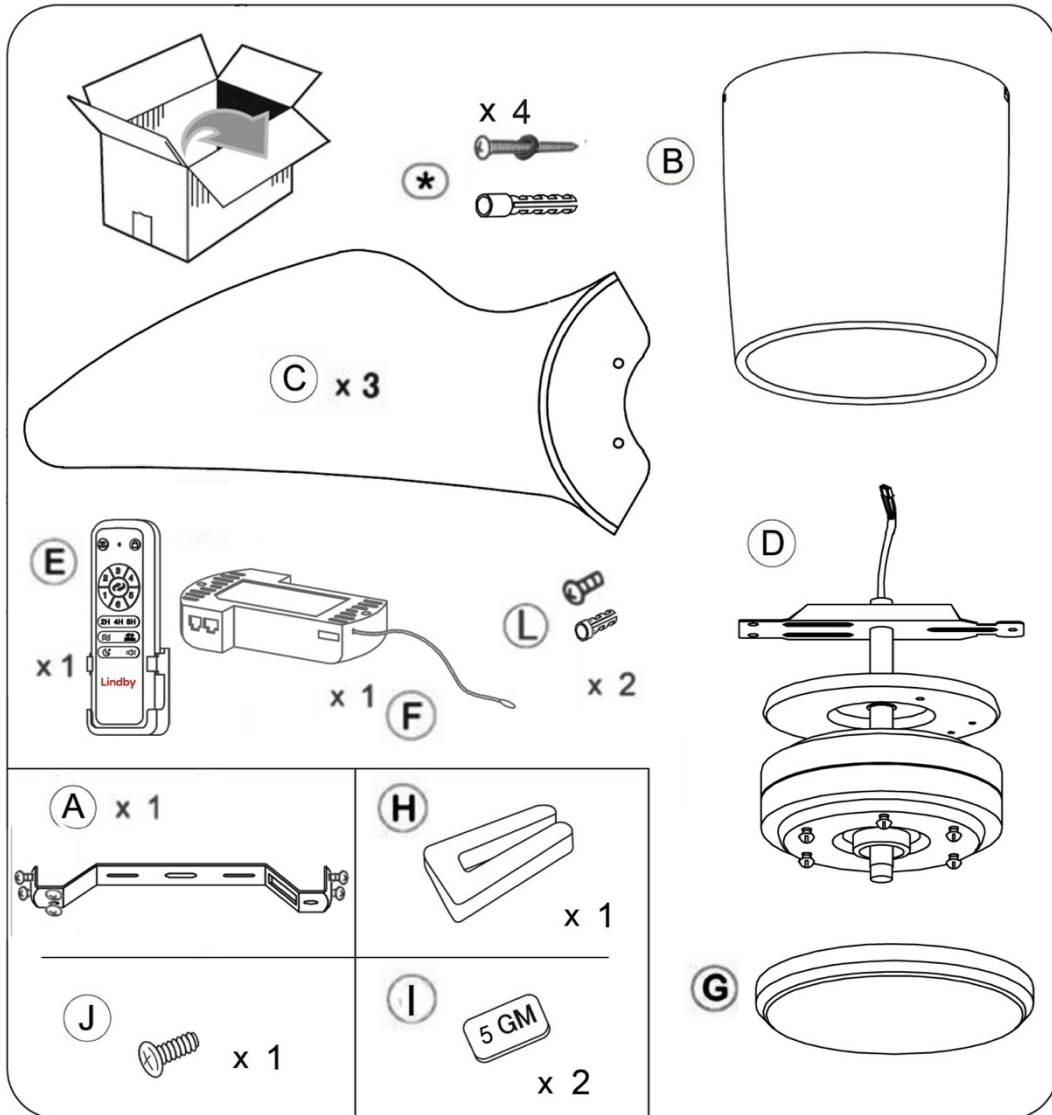
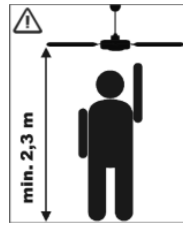
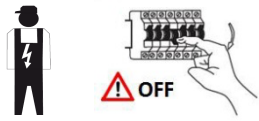



Use screws and dowels suited for your backing

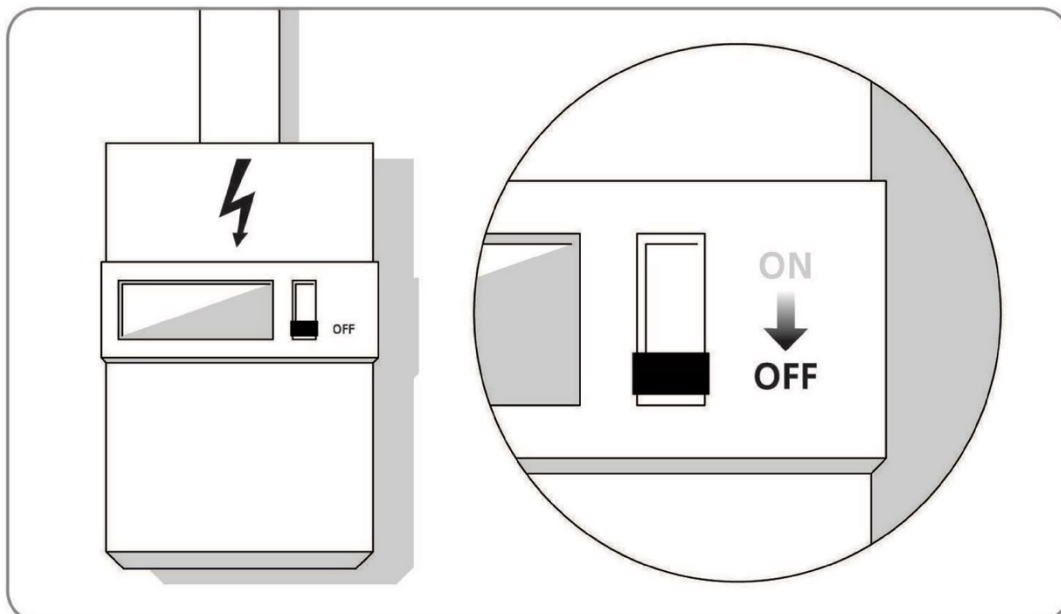
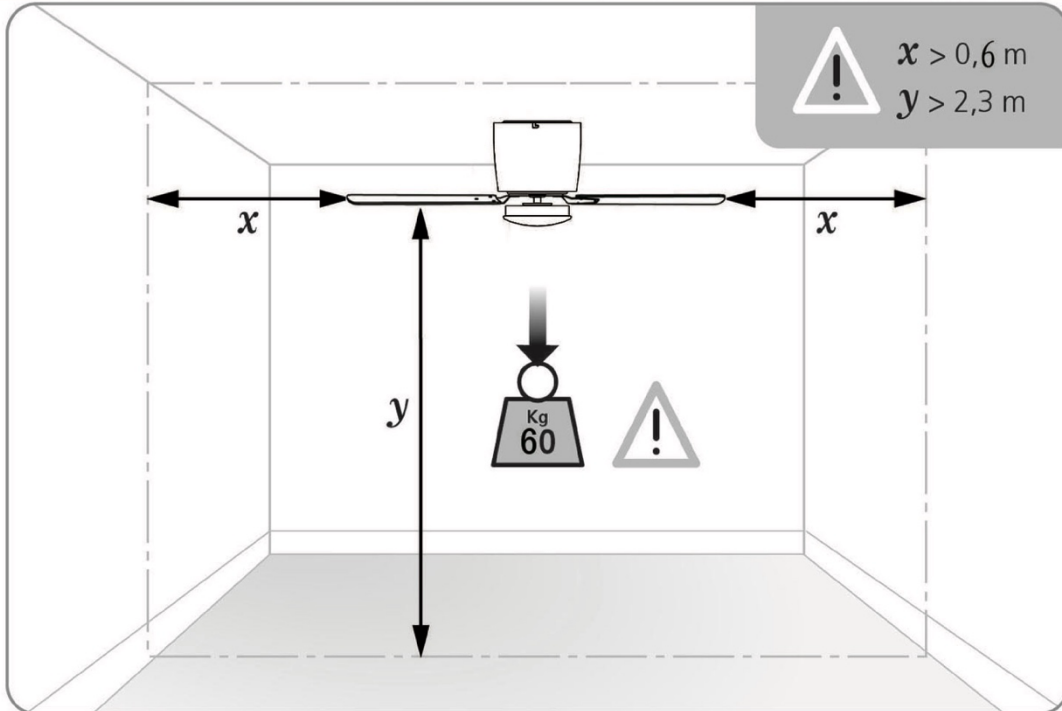

1

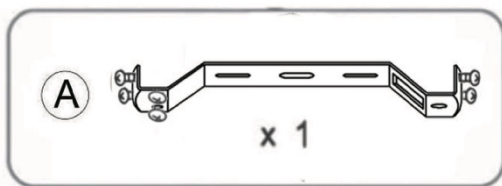
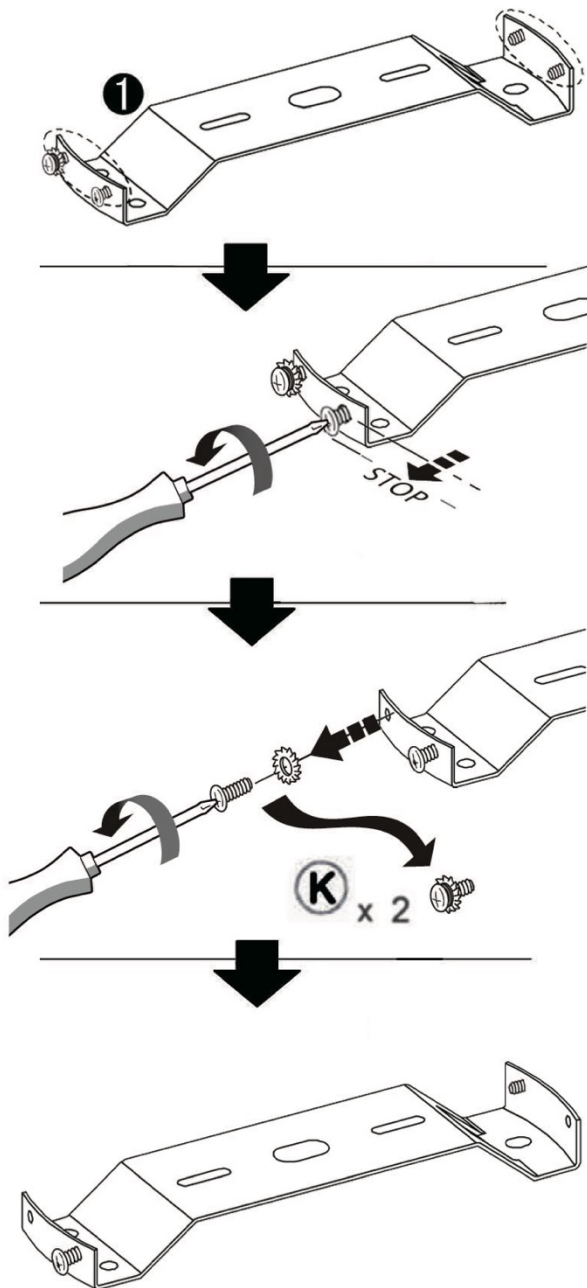

2

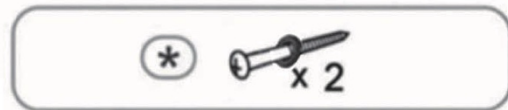
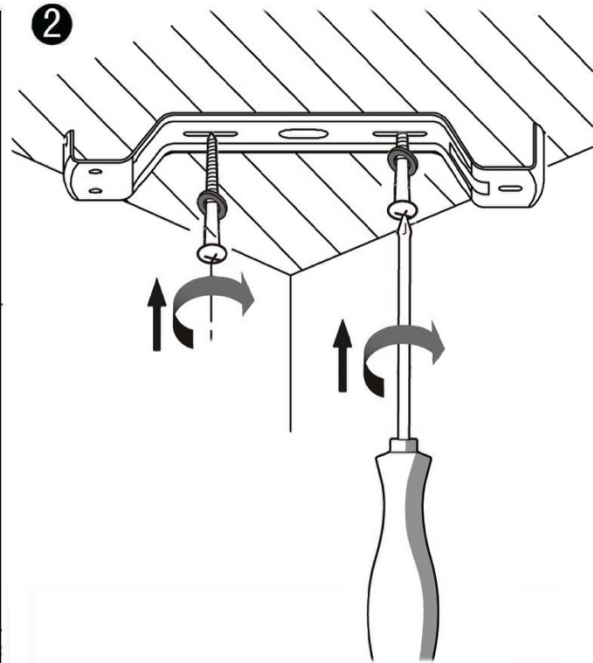

OR

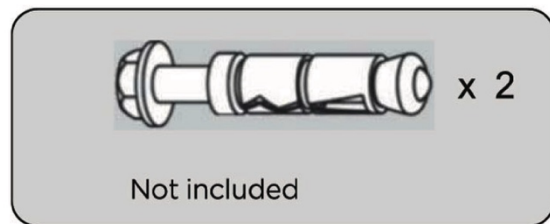
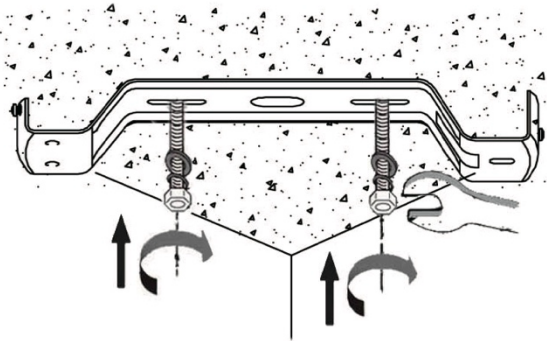

2

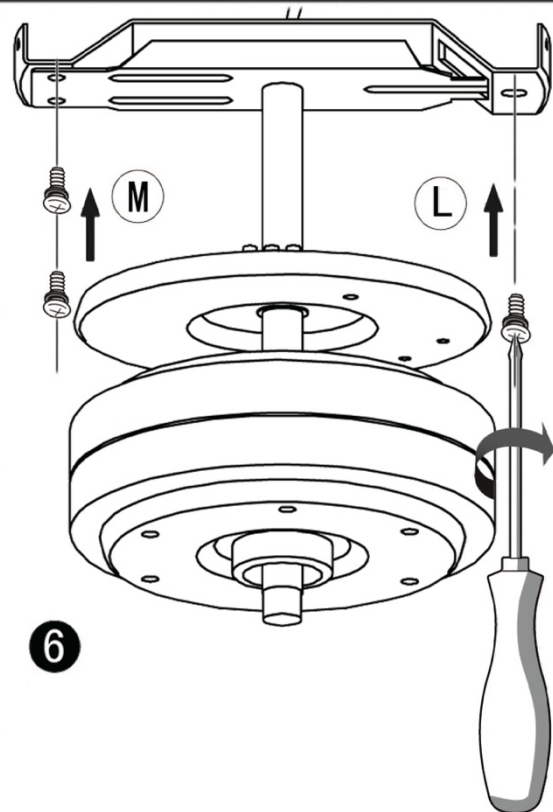
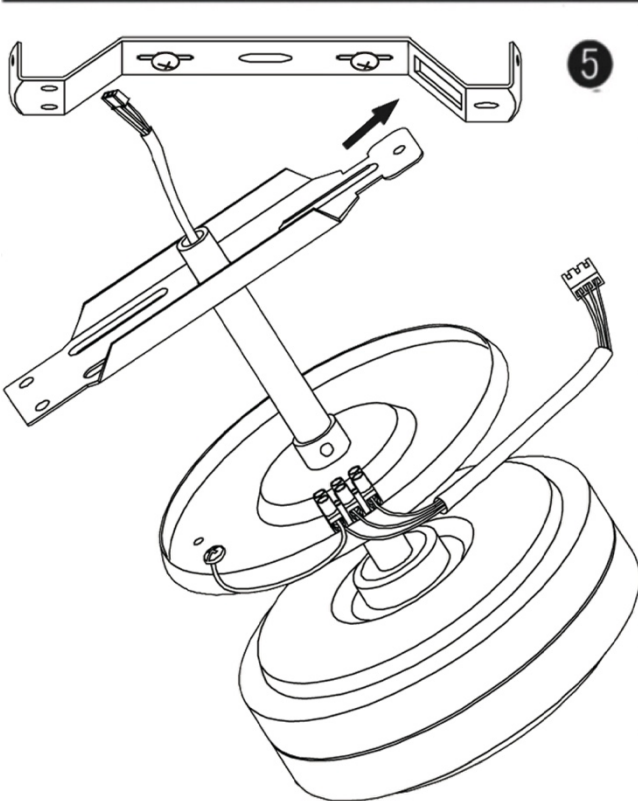
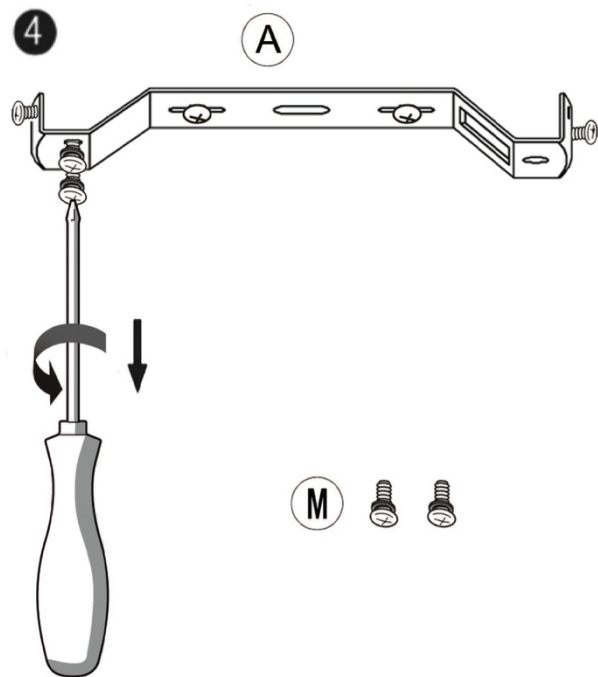
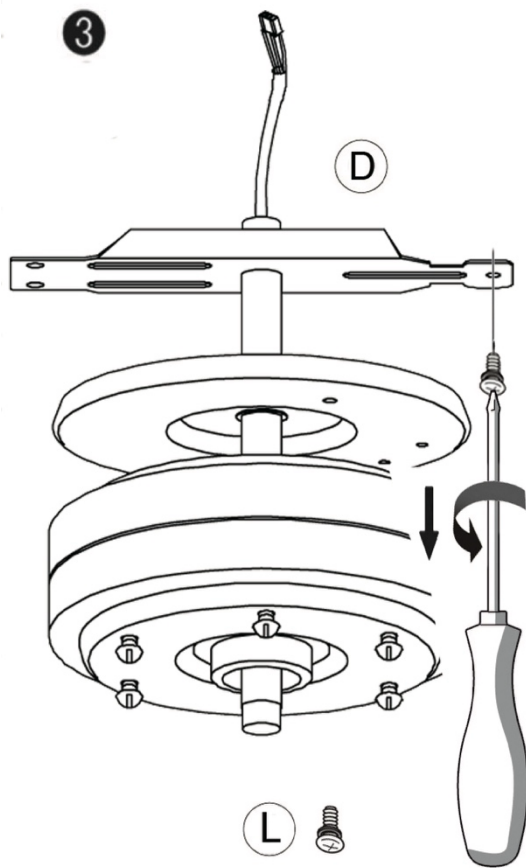

3

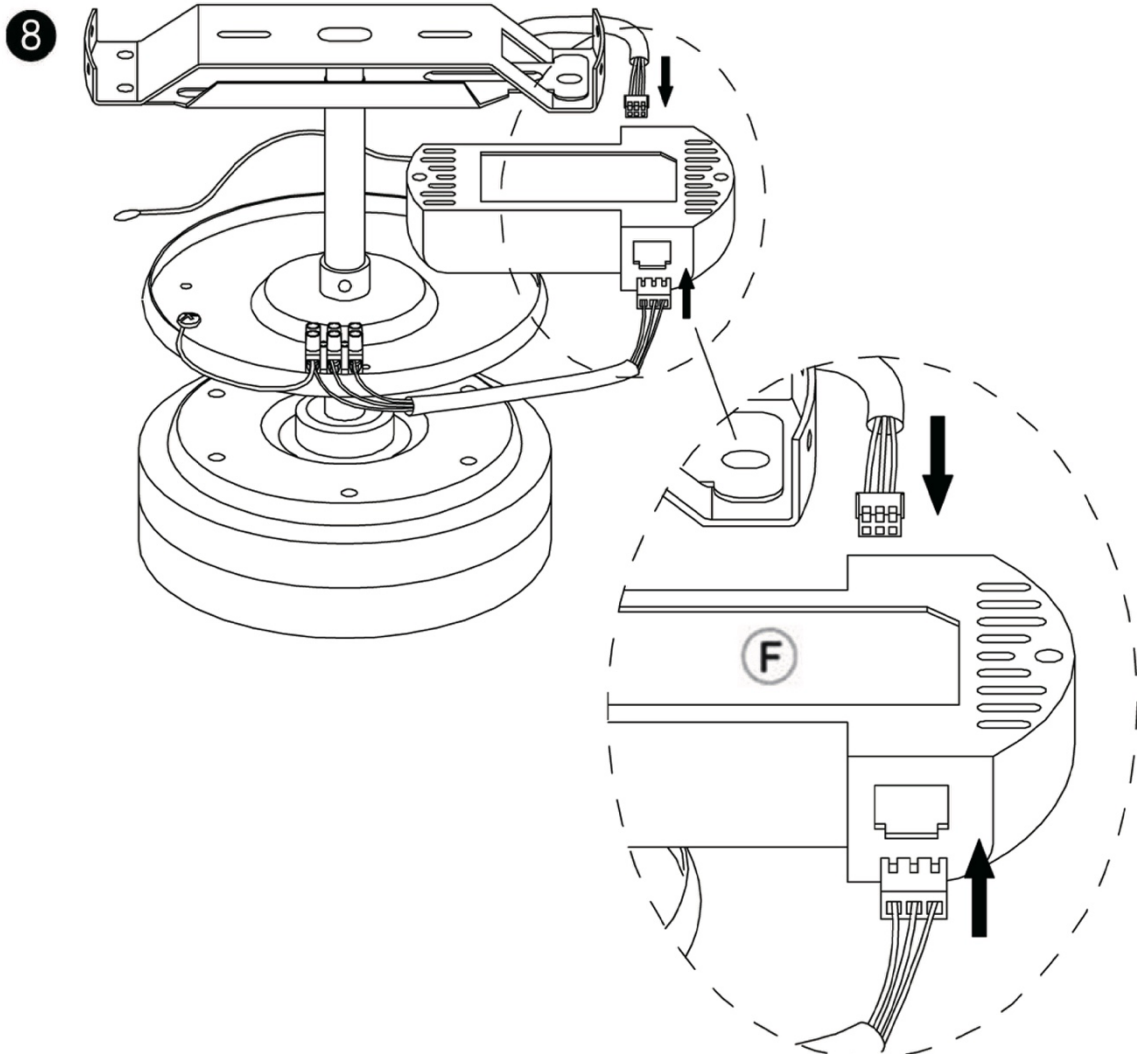
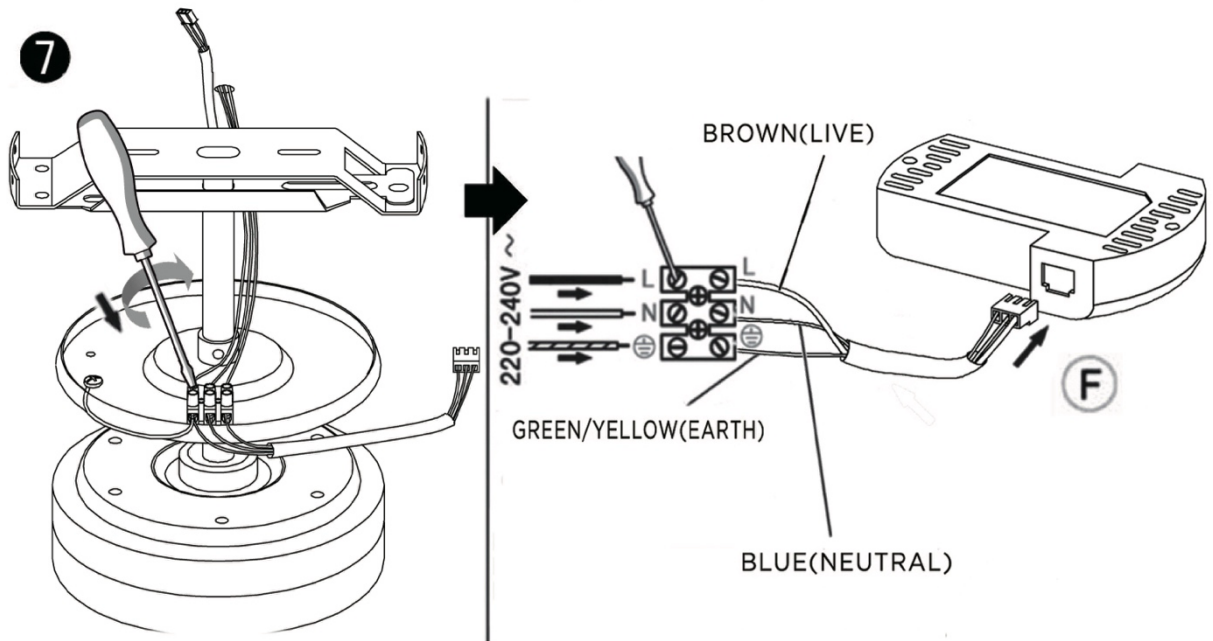

4

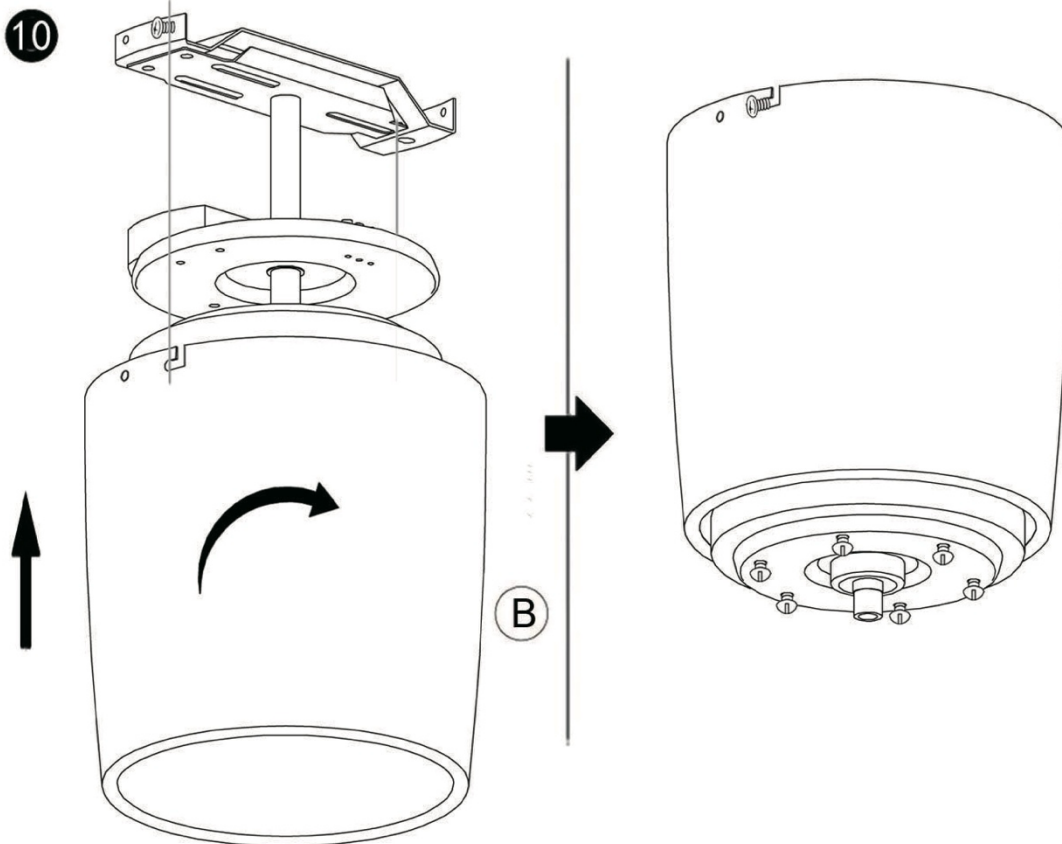
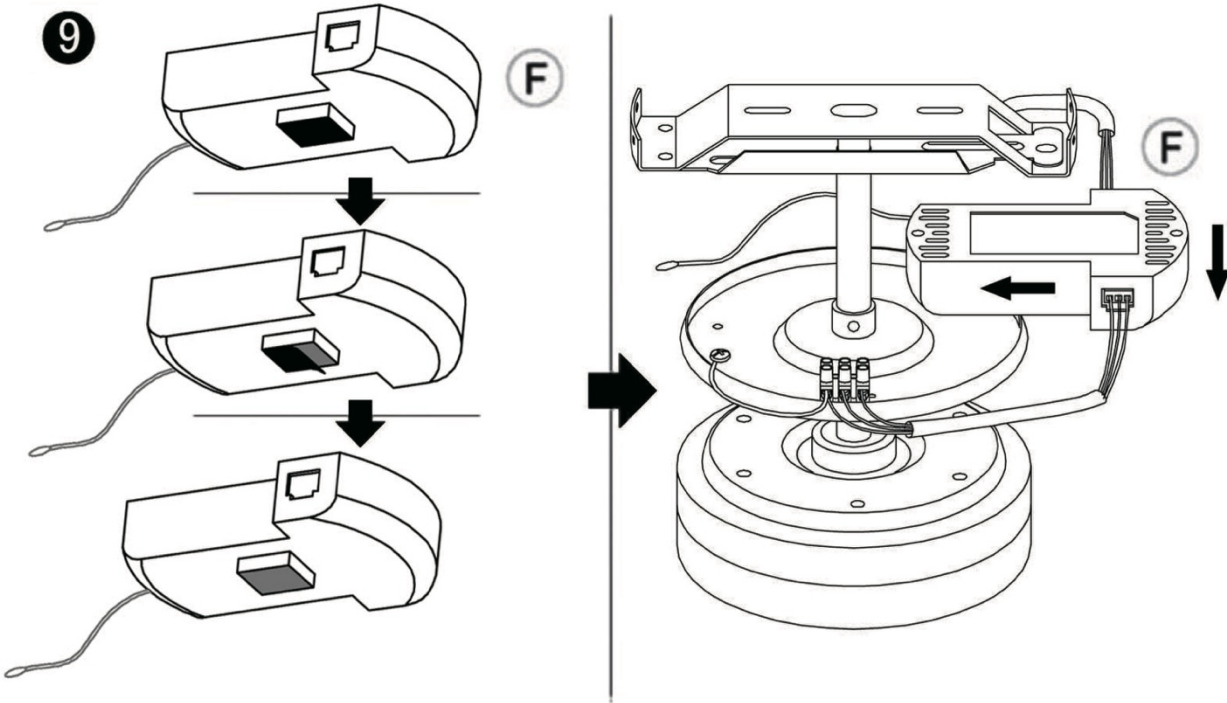

4

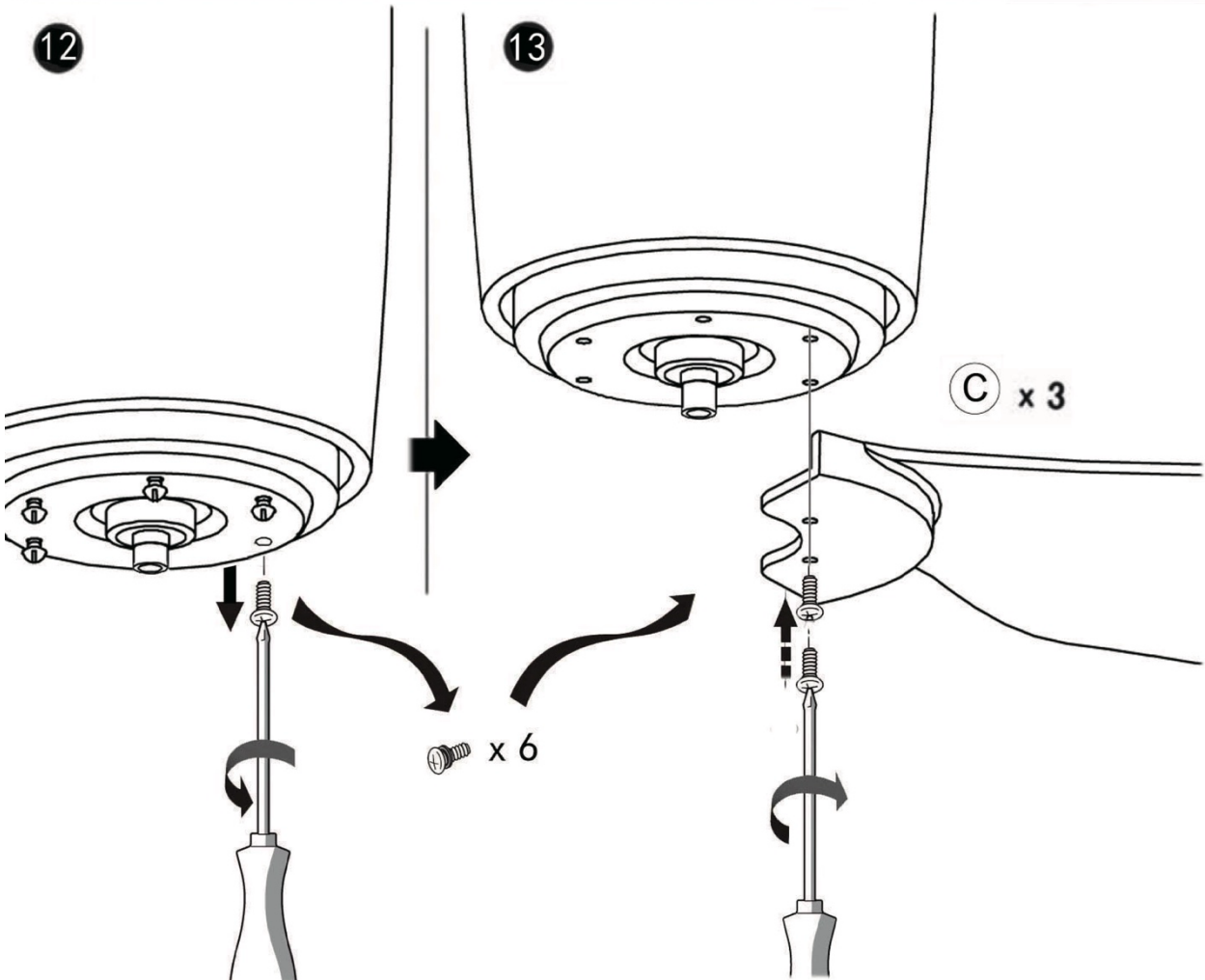
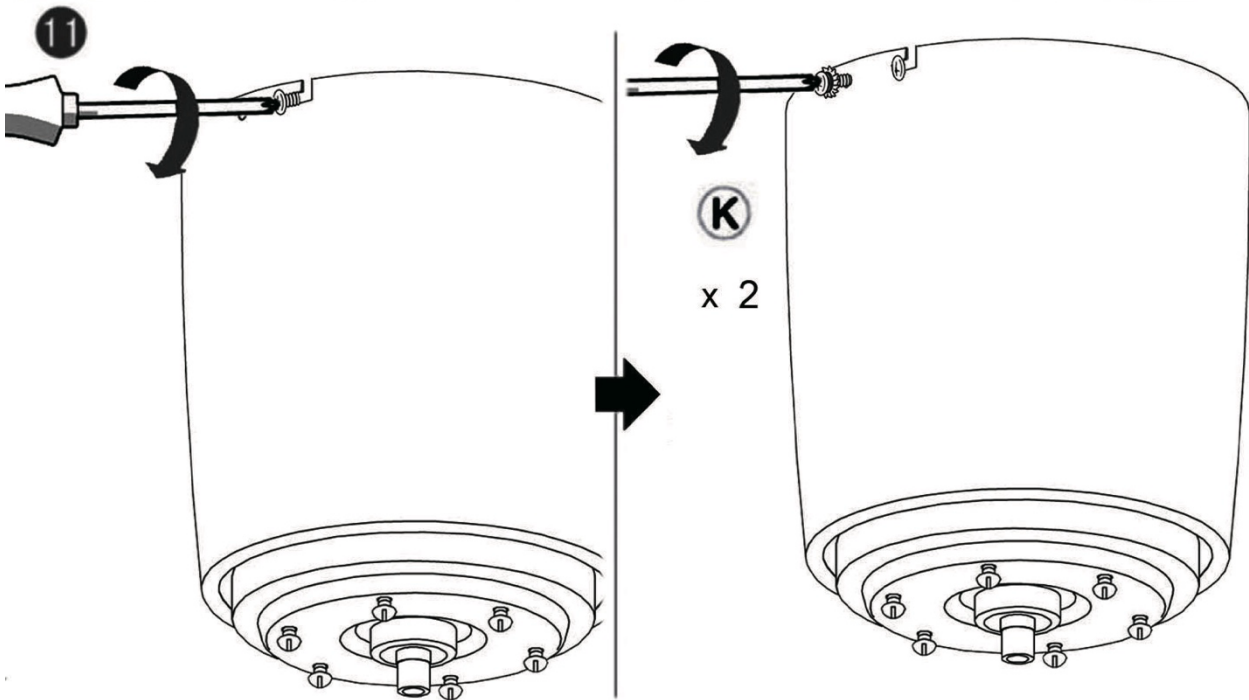

5

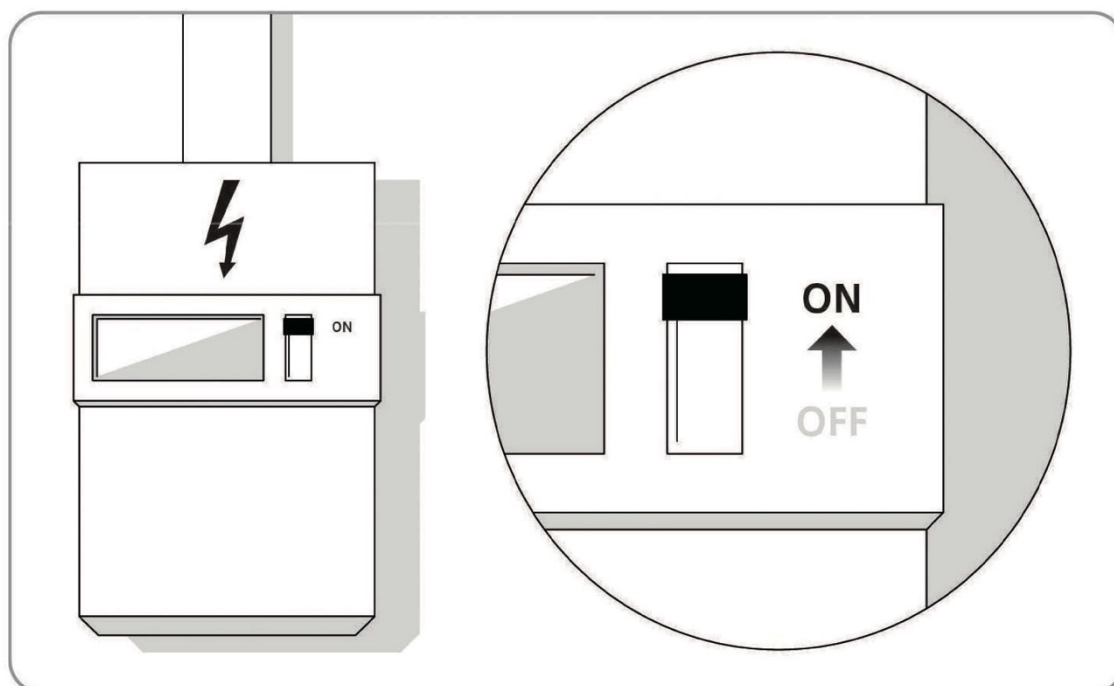
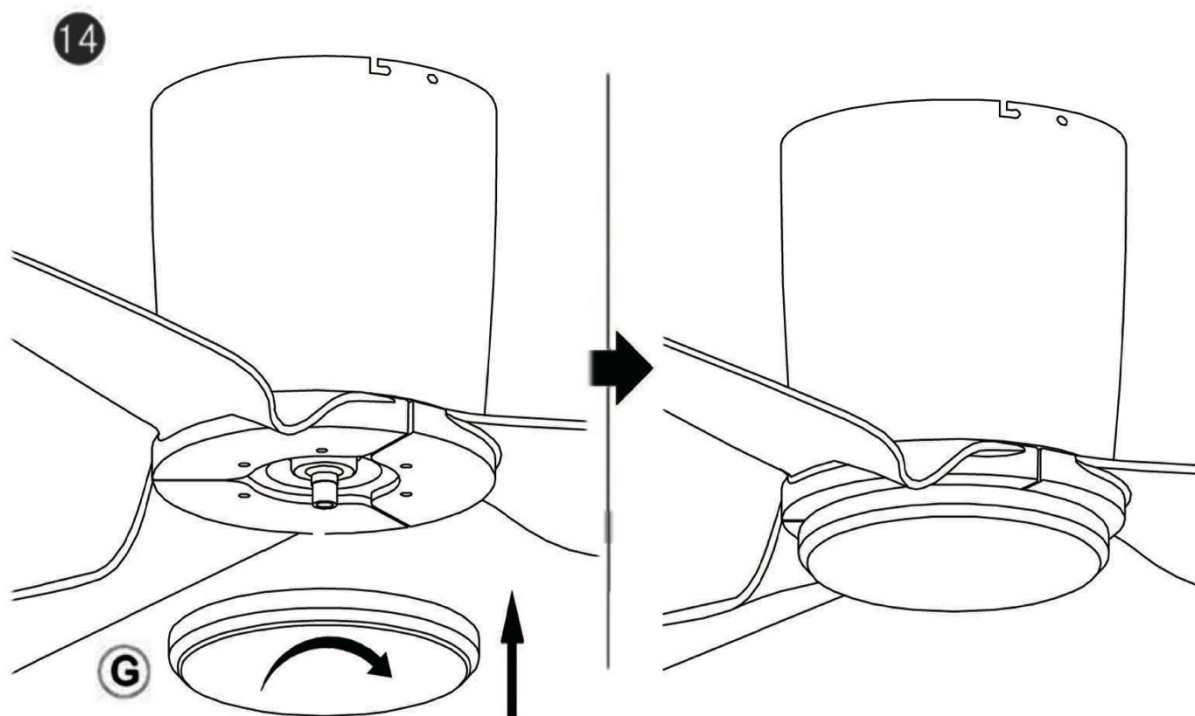

27

H

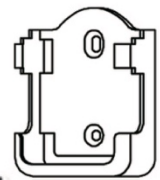

28

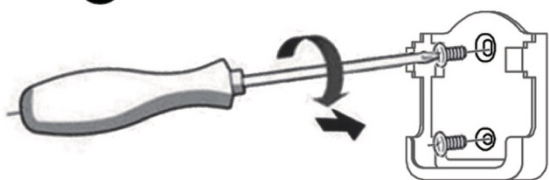

H

x 1

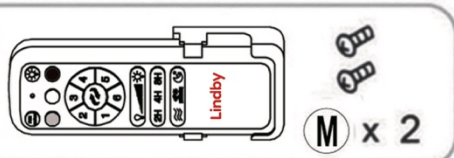

M

x 2

29

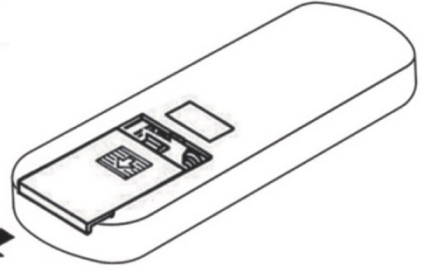

30

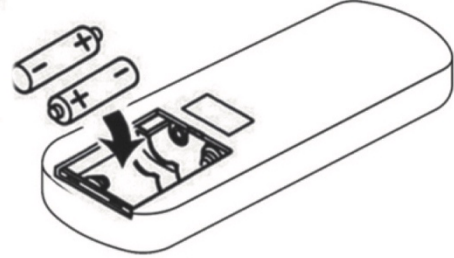

31

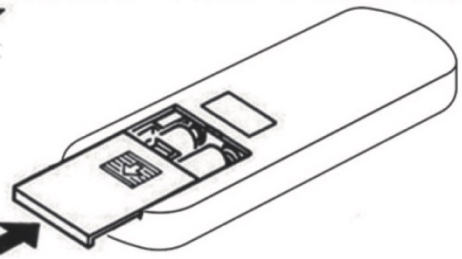

32

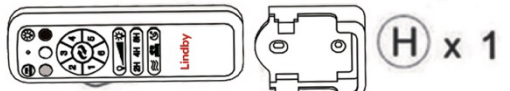
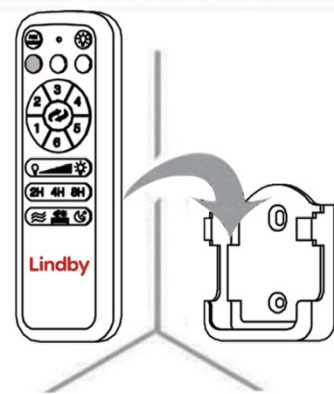



H x 1

AAA Not included  
x2



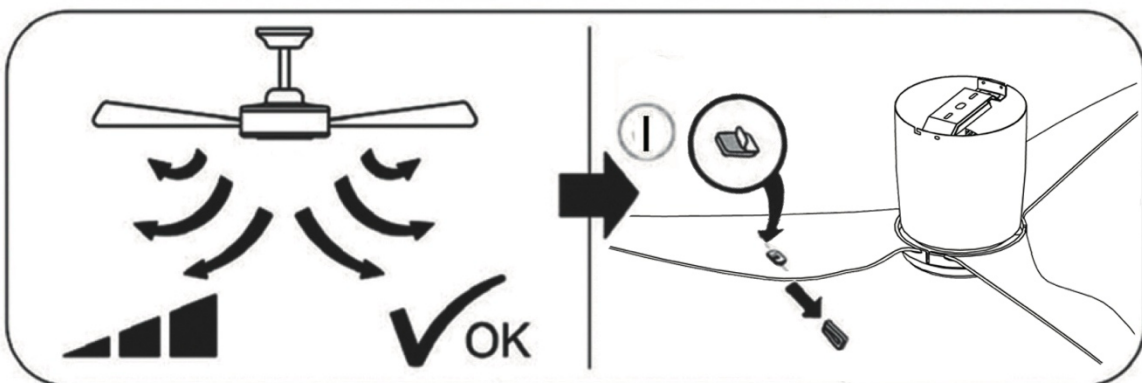
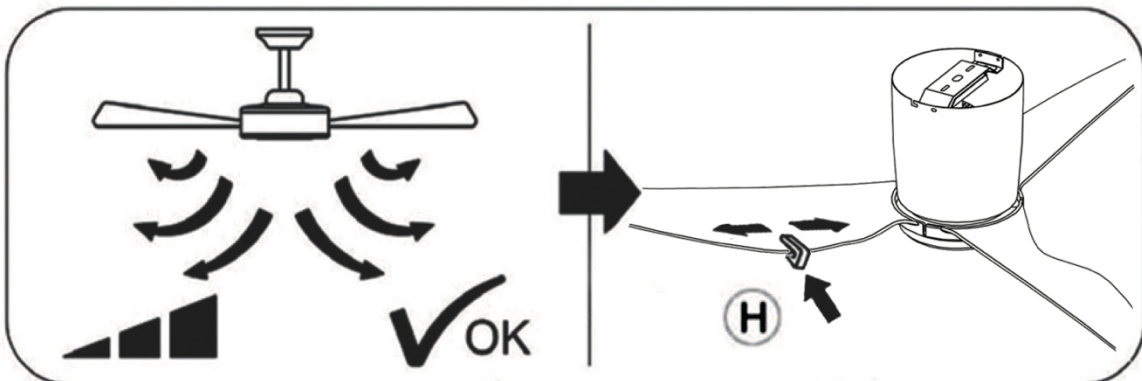
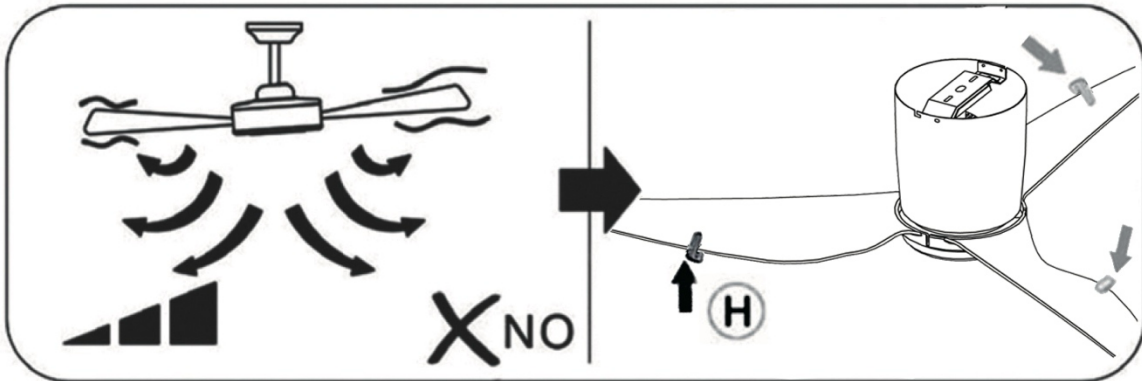
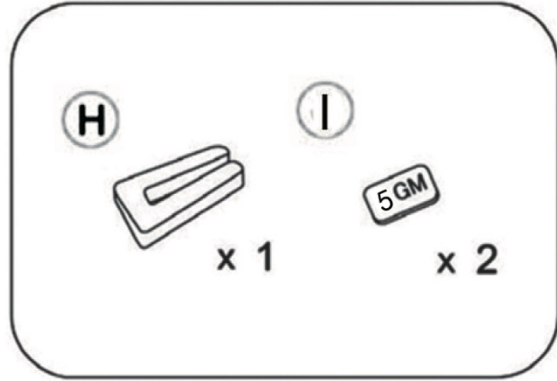
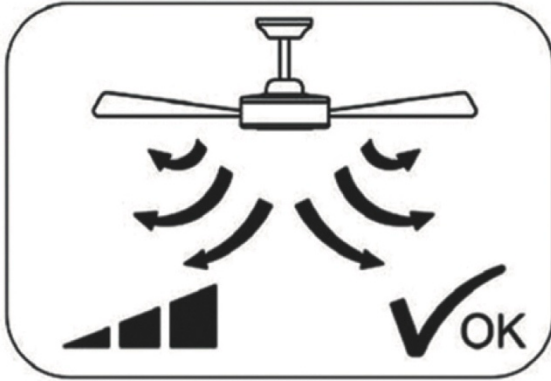

Button	Function
	Fan On/Off
0	Indicator Light
	Light On/Off
	3000K
	4000K
	6500K
1	Fan ON with Speed level 1 (the lowest speed)
2	Fan ON with Speed level 2
3	Fan ON with Speed level 3
4	Fan ON with Speed level 4
5	Fan ON with Speed level 5
6	Fan ON with Speed level 6 (the highest speed)
	Decrease brightness
	Increase brightness
2H	Timer:Product turns OFF after 2 hours
4H	Timer:Product turns OFF after 4 hours
8H	Timer:Product turns OFF after 8 hours
	Natural Breeze
	Security Deterrent Light / Vacation Mode
	Sleep Mode

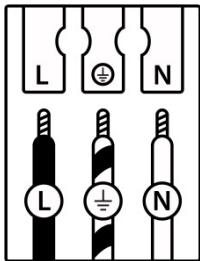

	(DE)	(EN)	(FR)	(NL)	(PL)	(NO)
<b>L</b>	Stromführender Leiter	Live conductor	Conducteur	Spanningvoerende draad	Przewód prądowy	Strømførende leder
	Schutzleiter	Earth conductor	Conducteur de protection (terre)	Aardkabel	Przewód uziemiający	Jordledningen
<b>N</b>	Neutralleiter	Neutral conductor	Conducteur neutre	Nulleider	Przewód zerowy	Nøytralleider

	(DK)	(SE)	(FI)	(IT)	(ES)	(CZ)
<b>L</b>	Strømførende leder	Strömförande ledare	Virtajohdin	Conduttore sotto tensione	Conductor de corriente	Vodič pod napětím
	Jordledningen	Skyddsledare	Suojajohdin	Conduttore di terra	Conductor de protección	Ochranný vodič
<b>N</b>	Neutralleider	Neutralledare	Nollajohdin	Conduttore neutro	Conductor neutro	Neutrální vodič



	(PT)	(GR)	(SK)	(EE)	(LV)	(LT)
<b>L</b>	Condutor vivo	Ρευματοφόρος αγωγός	Živý vodič	Faasisjuht	Dzīvais vadītājs	Gyvas dirigentas
	Condutor de terra	Αγωγός γείωσης	Zemný vodič	Maandusjuht	Zemes vadītājs	Žemės dirigentas
<b>N</b>	Condutor neutro	Ουδέτερος αγωγός	Neutrálny vodič	Neutraaljuht	Neitrālais vadītājs	Neutrinis dirigentas

	(RO)	(SI)	(HR)	(HU)	(BG)	(AL)
<b>L</b>	Conductor viu	Živi dirigent	Živi dirigent	Élő vezető	проводник под напряжение	Konduktor i gjallë
	Conductor de împământare	Zemeljski dirigent	Uzemljeni dirigent	Földvezető	защитен проводник	Dirigjent i tokës
<b>N</b>	Conductor neutru	Neutralni dirigent	Neutralni dirigent	Semleges vezető	нулев проводник	Kondaktor neutral

	(MK)	(TR)	(UK)	(BA)(ME)(RS)
<b>L</b>	Жив кондуктор	Canlı yönetici	Живий диригент	Živi dirigent
	Земјен проводник	Toprak iletkeni	Земельний провідник	Zemaljski provodnik
<b>N</b>	Неутрален проводник	Nötr iletken	Нейтральний провідник	Neutralni provodnik

### (DE) Verwendete Symbole

(EN) Safety Precautions | (FR) Symboles utilisés | (NL) Gebruikte symbolen | (PL) Stosowane symbole | (NO) Brukte symboler | (DK) Brugte symboler | (SE) Använda symboler | (FI) Käytetyt symbolit | (IT) Simboli usati | (ES) Símbolos empleados | (CZ) Použité symboly | (PT) Símbolos utilizados | (GR) Χρησιμοποιούμενα σύμβολα | (SK) Bezpečnostné opatrenia | (EE) Ohutusabinõud | (LV) Drošības pasākumi | (LT) Saugos priemonės | (RO) Măsuri de precauție | (SI) Varnostni ukrepi | (HR) Mjere opreza | (HU) Használt szimbólumok | (BG) Мерки за безопасност | (AL) Simbolet e përdorura | (MK) Користени симболи | (TR) Kullanılan semboller | (UK) Використовувані символи | (BA,ME,RS) Korišteni simboli

IP 20

