

**10027067**

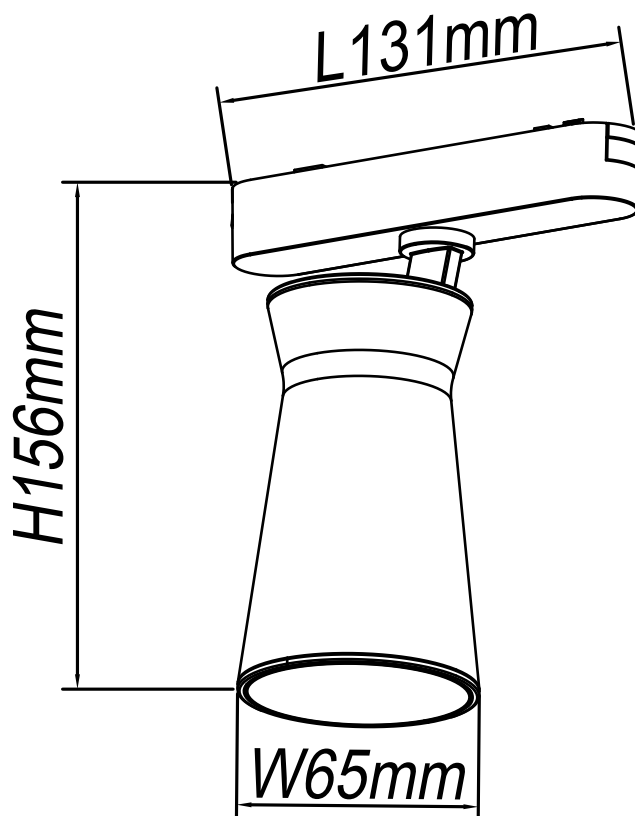



7,7W LED / 8,5W Total  
incl. LED Board: L9002976  
48Vdc constant voltage / 0,177A



**(DE) Bestimmungsgemäße Verwendung**

(EN) Intended use | (FR) Utilisation conforme | (NL) Beoogd gebruik | (PL) Stosowanie zgodnie z przeznaczeniem | (NO) Riktig bruk | (DK) Korrekt brug  
(SE) Avsedd användning | (FI) Määräystenmukainen käyttö | (IT) Impiego appropriato | (ES) Uso prescrito | (CZ) Použití v souladu s určením  
(PT) Utilização correta | (GR) Ενδεδειγμένη χρήση | (SK) Predpokladané použitie | (EE) Eeldatav kasutus | (LV) Paredzams lietojums  
(LT) Numatomas naudojimas | (RO) Utilizare intenționată | (SI) Predvidena uporaba | (HR) Namjenska upotreba | (HU) Tervezett felhasználás  
(BG) предназначена употреба | (AL) Përdorimi i parashikuar | (MK) Предвидена употреба | (TR) Amaçlı kullanım | (UK) Призначене використання  
(BA,ME,RS) Namjenska upotreba

(DE)	Verwendung als Schienenleuchte im Innenbereich	(GB)	Use as a track light indoors
(FR)	Utilisation comme luminaire sur rail en intérieur	(NL)	Gebruik als railverlichting binnenshuis
(PL)	Użycie jako oświetlenie szynowe wewnątrz	(NO)	Bruk som skinnelysning innendørs
(DK)	Brug som skinnelysning indendørs	(SE)	Användning som skinnelysning inomhus
(FI)	Käyttö kiskoalajaisena sisätiloissa	(IT)	Utilizzo come illuminazione su binario per interni
(ES)	Uso como luz de riel en interiores	(CZ)	Použití jako kolejové osvětlení v interiéru
(PT)	Uso como iluminação de trilho em interiores	(GR)	Χρήση ως φωτιστικό λάμπα εσωτερικού χώρου
(SK)	Použitie ako koľajové svetlo v interiéri	(BG)	Използване като релсова светлина на закрито
(EE)	Kasutamine rööbasteevalgustina siseruumides	(LV)	Izmantošana kā sliežu apgaismojums iekštelpās
(LT)	Naudojimas kaip bėgių šviestuvų patalpose	(RO)	Utilizare ca lumină pe șină în interior
(SI)	Uporaba kot tirna svetilka v notranjih prostorih	(HR)	Korištenje kao tračna svjetiljka u unutrašnjosti
(HU)	Használat sínvilágításként beltérben	(AL)	Përdorimi si ndriçim hekurudhor brenda
(MK)	Употреба како шинско светло во внатрешноста	(TR)	İç mekanda raylı aydınlatma olarak kullanım
(UK)	Використання як рейкове освітлення в приміщенні	(BA)	Korištenje kao željezničko svjetlo u unutrašnjosti
		(ME)	
		(RS)	

(DE) Lieferumfang		
(EN) Package contents   (FR) Contenu de la livraison   (NL) Bij de levering inbegrepen   (PL) Zakres dostawy   (NO) Levering   (DK) Leveringsomfang (SE) Leveransomfattning   (FI) Toimitussisältö   (IT) Fornitura   (ES) Volumen de suministro   (CZ) Rozsah dodávky   (PT) Material fornecido (GR) Παραδοτέος εξοπλισμός   (SK) Obsah balenia   (EE) Pakendi sisu   (LV) Pakas saturs   (LT) Pakuotės turinys (RO) Conținutul pachetului   (SI) Vsebina paketa   (HR) Sadržaj paketa   (HU) A csomag tartalma   (BG) обхват на доставката (AL) Përmbajtja e dorëzimit   (MK) Содржина на испорака   (TR) Teslimat içeriği   (UK) Зміст доставки   (BA,ME,RS) Sadržaj isporuke		
(DE) 1 Schienenleuchte Montagematerial Montageanleitung	(GB) 1 track light Installation hardware Mounting instructions	(FR) 1 luminaire sur rail Matériel de montage Instructions de montage
(NL) 1 railverlichtin Monteringsmateriale Montagehandleiding	(PL) 1 oświetlenie szynowe Elementy montażowe Instrukcja montażu	(NO) 1 skinnebelysning Monteringsmateriale Brukerveiledning
(DK) 1 skinnebelysning Monteringsmateriale Brugervejledning	(SE) 1 skenbelysning Monteringsmaterial Monteringsanvisning	(FI) 1 kiskoalaisin Asennus materiaali Asennusohjeet
(IT) 1 illuminazione su binario Materiale di montaggio Istruzioni di montaggio	(ES) 1 luz de riel Material de montaje Instrucciones de montaje	(CZ) 1 kolejové osvětlení Materiál pro montáž Návod k montáži
(PT) 1 iluminação de trilho Material de montagem Instruções de montagem	(GR) 1 φωτιστικό ράγας Υλικό συναρμολόγησης Οδηγίες συναρμολόγησης	(SK) 1 koľajové svetlo Inštalčný hardvér Inštalčná príručka
(BG) 1 релсова светлина материали за монтаж инструкции за монтаж	(EE) 1 rööbasteevalgusti Paigaldustarvikud Paigaldusjuhend	(LV) 1 sliežu apgaismojums Instalācijas aparātūra Uzstādīšanas instrukcija
(LT) 1 bėgių šviestuvai Montavimo aparatinė įranga Montavimo instrukcija	(RO) 1 lumină pe șină Hardware de instalare Instrucțiuni de montare	(SI) 1 tirna svetilka Namestitvena strojna oprema Navodila za montažo
(HR) 1 tračna svjetiljka Instalacijski hardver Upute za montažu	(HU) 1 sínvilágítás Telepítési hardver Szerelési útmutató	(AL) 1 ndriçim hekurudhor Materiali i montimit Udhëzuesi i montimit
(MK) 1 шинско светло Монтажен материјал Упатство за монтажа	(TR) 1 raylı aydınlatma Montaj malzemesi Montaj kılavuzu	(UK) 1 рейкове освітлення Монтажний матеріал Інструкція з монтажу
(BA) 1 željezničko svjetlo (ME) Montažni materijal (RS) Uputstvo za montažu		

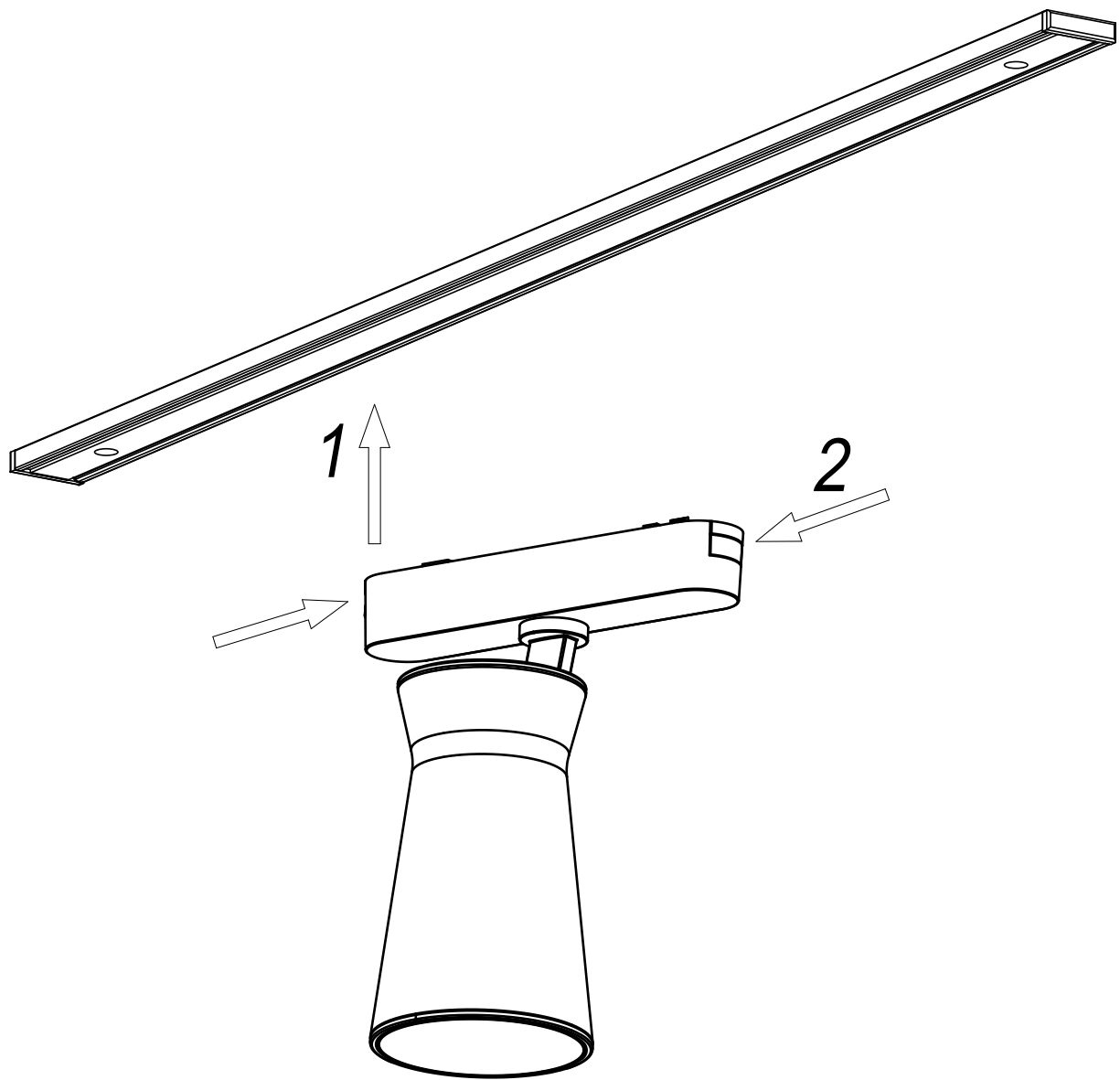
(DE) Verwendete Symbole	
(EN) Safety Precautions   (FR) Symboles utilisés   (NL) Gebruikte symbolen   (PL) Stosowane symbole   (NO) Brukte symboler   (DK) Brugte symboler (SE) Använda symboler   (FI) Käytetyt symbolit   (IT) Simboli usati   (ES) Símbolos empleados   (CZ) Použité symboly   (PT) Símbolos utilizados (GR) Χρησιμοποιούμενα σύμβολα   (SK) Bezpečnostné opatrenia   (EE) Ohutusabinõud   (LV) Drošības pasākumi (LT) Saugos priemonės   (RO) Măsuri de precauție   (SI) Varnostni ukrepi   (HR) Mjere opreza   (HU) Használt szimbólumok   (BG) Мерки за безопасност (AL) Simbolet e përdorura   (MK) Користени симболи   (TR) Kullanılan semboller   (UK) Використовувані символи   (BA,ME,RS) Korišteni simboli	
IP 20	   

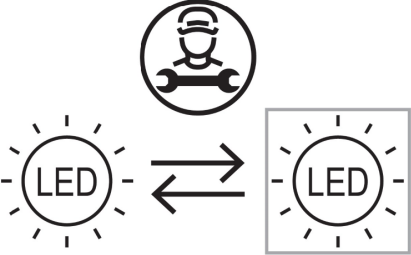

<p>(DE) Dieses Produkt enthält eine Lichtquelle der Energieeffizienzklasse F  (EN) This product contains a light source of energy efficiency class F  (FR) Ce produit comprend une source de lumière de classe d'efficacité énergétique F  (NL) Dit product bevat een lichtbron van energie-efficiëntieklasse F  (PL) Produkt ten zawiera źródło światła o klasie efektywności energetycznej F  (NO) Dette produktet inneholder en lyskilde i energieeffektivitetsklasse F  (DK) Dette produkt indeholder en lyskilde af energieeffektklasse F  (SE) Denna produkt innehåller en ljuskälla i energieffektivitetsklass F  (FI) Tämä tuote sisältää energiatehokkuusluokan F valonlähteen  (IT) Questo prodotto contiene una sorgente luminosa della classe di efficienza energetica F  (ES) Este producto contiene una fuente de luz de la clase de eficiencia energética F  (CZ) Tento výrobek obsahuje světelný zdroj třídy energetické účinnosti F  (PT) Este produto contém uma fonte de luz da classe de eficiência energética F  (GR) Αυτό το προϊόν περιέχει μια φωτεινή πηγή ενεργειακής απόδοσης κλάσης F  (SK) Tento výrobok obsahuje zdroj svetla triedy energetickej efektivity F  (EE) See toode sisaldab energiatõhususklassi F valgusallikat  (LV) Šis produkts satur enerģijas efektivitātes klases F gaismas avotu  (LT) Šis gaminys turi energijos efektyvumo klasės F šviesos šaltinį  (RO) Acest produs conține o sursă de lumină de clasă de eficiență energetică F  (SI) Ta izdelek vsebuje svetlobni vir energijskega razreda F  (HR) Ovaj proizvod sadrži izvor svjetlosti energetske učinkovitosti klase F  (HU) Ez a termék egy F energiahatékonysági osztályú fényforrást tartalmaz  (BG) Този продукт съдържа източник на светлина с клас на енергийна ефективност: F  (AL) Ky produkt përmban një burim drite të klasës së efikasitetit të energjisë F  (MK) Овој производ содржи извор на светлина од класа на енергетска ефикасност F  (TR) Bu ürün, enerji verimliliği sınıfı F olan bir ışık kaynağı içerir  (UK) Цей продукт містить джерело світла класу енергоефективності F  (BA)(ME)(RS) Ovaj proizvod sadrži izvor svjetlosti energetske klase F</p>	<p>QR</p> 	<p>EAN</p> <p>4251911790511</p>
--	---	---------------------------------

	<p>(DE) Durch einen Fachmann austauschbare Lichtquelle (nur LED).  (EN) Replaceable (LED only) light source by a professional.  (FR) Source de lumière remplaçable (LED uniquement) par un professionnel.  (NL) Lichtbron (alleen led) te vervangen door een professional.  (PL) Wymienne (tylko LED) źródło światła wykonane przez profesjonalistę.  (NO) Utskiftbar (kun LED) lyskilde av en profesjonell.  (DK) Udskiftelig lyskilde (kun LED), udskiftes af en elektriker.  (SE) Ljuskälla (endast LED) utbytbar genom fackman.  (FI) Ammatilainen voi vaihtaa vaihdettavan (vain LED) valonlähteen.  (IT) Sorgente luminosa (solo LED) sostituibile da un professionista.  (ES) Fuente de luz (solo LED) sustituible por un profesional.  (CZ) Vyměnitelný (pouze LED) světelný zdroj odborníkem.  (PT) Luz LED (apenas LED) substituível por um profissional.  (GR) Η πηγή φωτός (μόνο LED) να αντικαθίσταται από επαγγελματία.  (SK) Zdroj svetla (iba LED) vymeniteľný prostredníctvom odborníka.  (EE) Spetsialisti poolt vahetatav valgusallikas (ainult LED).  (LV) Speciālista maināms gaismas avots (tikai LED).  (LT) Specialisto keičiamas šviesos šaltinis (tik LED).  (RO) Sursă de lumină schimbabilă de către un specialist (doar LED).  (SI) Svetlobni vir, ki ga lahko zamenja strokovnjak (samo LED).  (HR) Izvor svjetlosti koji može zamijeniti stručnjak (samo LED).  (HU) Szakember által cserélhető (csak LED) fényforrás.  (BG) Светлинен източник, който може да се смени от специалист (само LED).  (AL) Burim drite i zëvendësueshëm (LED vetëm) nga një profesionist.  (MK) Изворот на светлина (само LED) се заменува од професионалец.  (TR) Değiştirilebilir (yalnızca LED) ışık kaynağı bir profesyonel tarafından değiştirilir.  (UK) Замінний (тільки LED) джерело світла замінюється фахівцем.  (BA)(ME)(RS) Zamjenjiv (samo LED) izvor svjetlosti zamjenjuje profesionalac.</p>
---	---

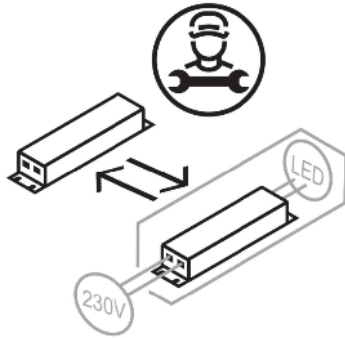

- (DE) Durch einen Fachmann austauschbares Betriebsgerät.  
 (EN) Replaceable control gear by a professional.  
 (FR) Contrôleur remplaçable par un professionnel.  
 (NL) Voorschakelapparatuur te vervangen door een professional.  
 (PL) Wymienny układ sterujący przez profesjonalistę.  
 (NO) Utskiftbar kontrollutstyr av en profesjonell.  
 (DK) Udskiftelig igangsætter, udskiftes af en elektriker.  
 (SE) Styrdon utbytbart genom fackman.  
 (FI) Ammattilainen voi vaihtaa vaihdettavat ohjauslaitteet.  
 (IT) Dispositivo di controllo sostituibile da un professionista.  
 (ES) Dispositivo de control sustituable por un profesional.  
 (CZ) Vyměnitelný předřadník odborníkem.  
 (PT) Dispositivo de controlo substituível por um profissional.  
 (GR) Ο εξοπλισμός ελέγχου να αντικαθίσταται από επαγγελματία.  
 (SK) Predradník vymeniteľný prostredníctvom odborníka.  
 (EE) Spetsialisti poolt vahetatav juhtseade.  
 (LV) Speciālista maināma vadības iekārta.  
 (LT) Specialisto keičiamas valdymo įrenginys.  
 (RO) Aparat de comandă schimbabil de către un specialist.  
 (SI) Nadomestna krmilna naprava, ki jo lahko zamenja strokovnjak.  
 (HR) Zamjenjivi upravljački sklop koji može zamijeniti stručnjak.  
 (HU) Szakember által cserélhető vezérlőszerkezet.  
 (BG) Уред, който може да се смени от специалист.  
 (AL) Pajisje kontrolli e zëvendësueshme nga një profesionist.  
 (MK) Заменлива контролна опрема од страна на професионалец.  
 (TR) Profesyonel tarafından değiştirilebilir kontrol donanımı.  
 (UK) Замінний контрольний пристрій фахівцем.  
 (BA)(ME)(RS) Zamjenjiva kontrolna oprema od strane profesionalca.