

LIGHT EFFICIENCY

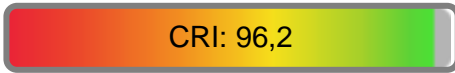

OUTPUT: 441 lm

LIGHT QUALITY



PEAK: 981 cd

COLOR TEMPERATURE

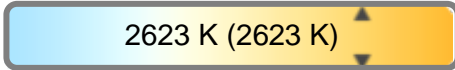

POWER: 5,9 W

PF: 0,52

DPF: 0,53

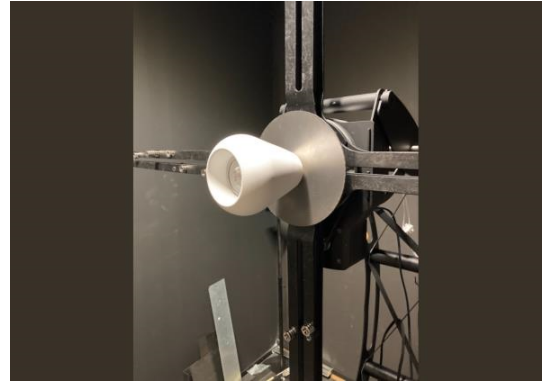

ITEM NUMBER:

2934

DATE AND TIME:

2024-02-09 08:05:15

DESCRIPTION:

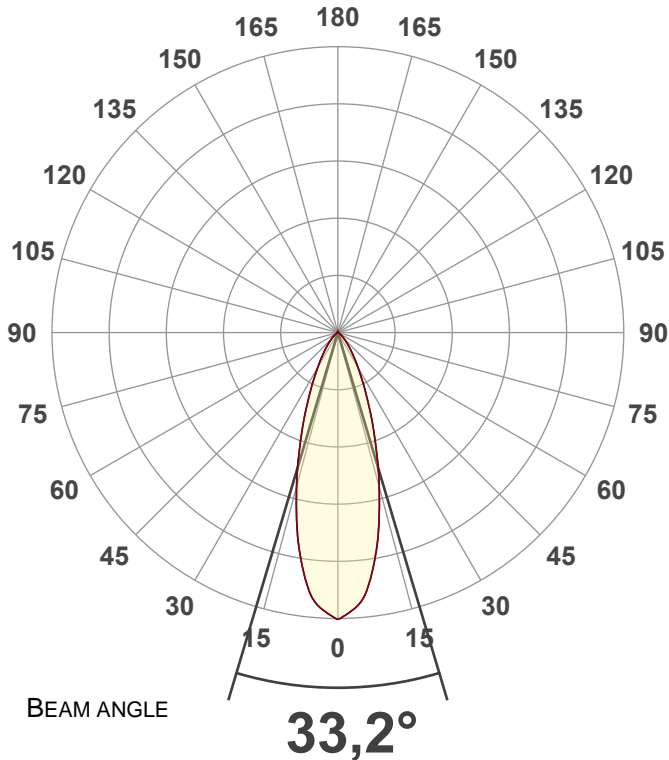

LUMEN OUTPUT IN 120° CONE: 431 lm

INTENSITY RATIO IN 120° CONE: 97,7

LUMEN OUTPUT IN 90° CONE: 411 lm

INTENSITY RATIO IN 90° CONE: 93,2

SPECTRAL DISTRIBUTION

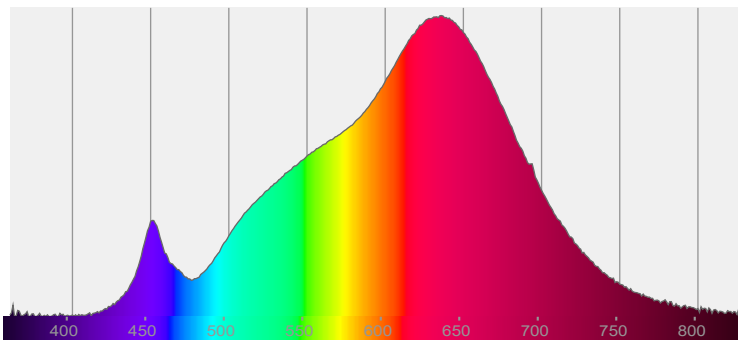

POWER

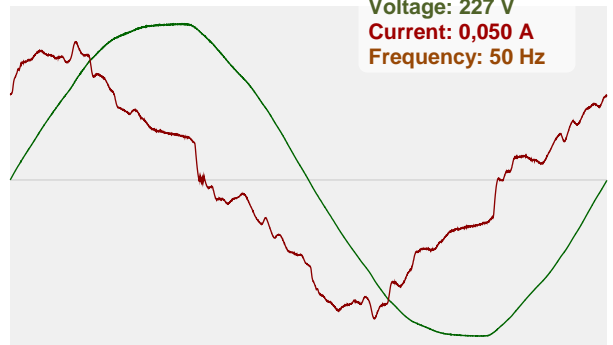

FILE NAME: Photometrics -2934 Nuura vit

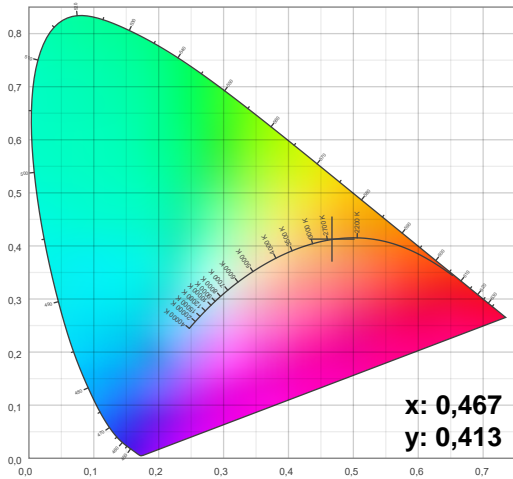

CIE 1931

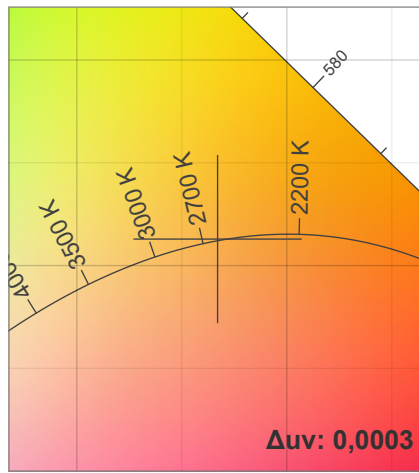

CIE 1931 ZOOM

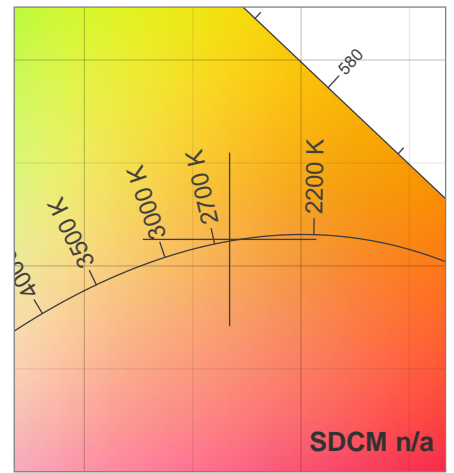

TM30: 94,2

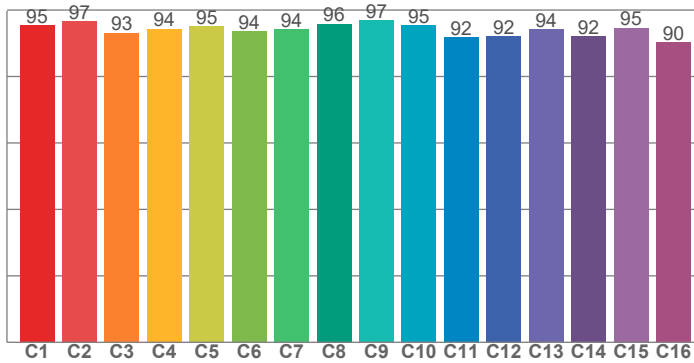

CRI: 96,2 (R1-R8)

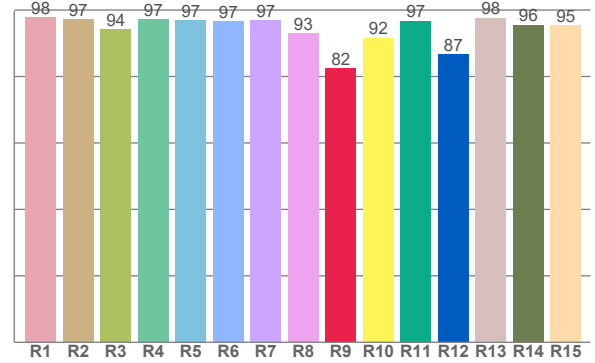

CQS: 92,6

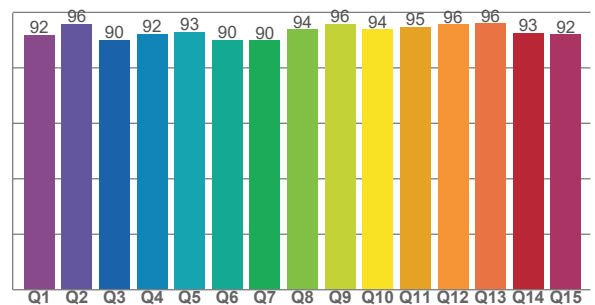

CRI R values, only R1-R8 are used to calculate final CRI value

R1	R2	R3	R4	R5	R6	R7	R8	R9	R10	R11	R12	R13	R14	R15
97,8	97,2	94,1	97,2	96,9	96,6	96,9	93,0	82,4	91,7	96,8	86,6	97,7	95,5	95,5

TM30 C values, 16 binned values out of total of 99 C values

C1	C2	C3	C4	C5	C6	C7	C8	C9	C10	C11	C12	C13	C14	C15	C16
95,4	96,6	93,1	94,3	95,1	93,5	94,2	95,8	96,8	95,4	91,7	92,1	94,2	92,0	94,6	90,3

CQS Q values

Q1	Q2	Q3	Q4	Q5	Q6	Q7	Q8	Q9	Q10	Q11	Q12	Q13	Q14	Q15
91,7	95,8	89,9	92,1	92,9	90,1	89,9	93,8	95,7	93,7	94,8	95,5	95,9	92,6	92,0

Color parameters

Color temperature	Color rendering index	Red component	Color fidelity	Color gamut	Color quality scale	Color coordinate cie 1931	Color coordinate cie 1931	Color coordinate	Color coordinate	Color diviation from black body
CCT	CRI	CRI R9	TM30 Rf	TM30 Rg	CQS	x	y	u	v	Δuv
2623 K	96,2	82,4	94,2	102,3	92,6	0,467	0,413	0,266	0,353	0,0003

Rf 94,2
Fidelity index Rf

Rg 102,3
Gammut index Rg

Hue Bin	R _f	Graphic shifts (%)	
		Chroma	Hue
1	95	-2%	-1%
2	97	-2%	1%
3	93	0%	3%
4	94	0%	3%
5	95	2%	3%
6	94	5%	1%
7	94	2%	-2%
8	96	1%	-3%
9	97	-1%	-1%
10	95	-1%	2%
11	92	1%	6%
12	92	3%	2%
13	94	3%	-2%
14	92	5%	-4%
15	95	1%	-3%
16	90	1%	-8%

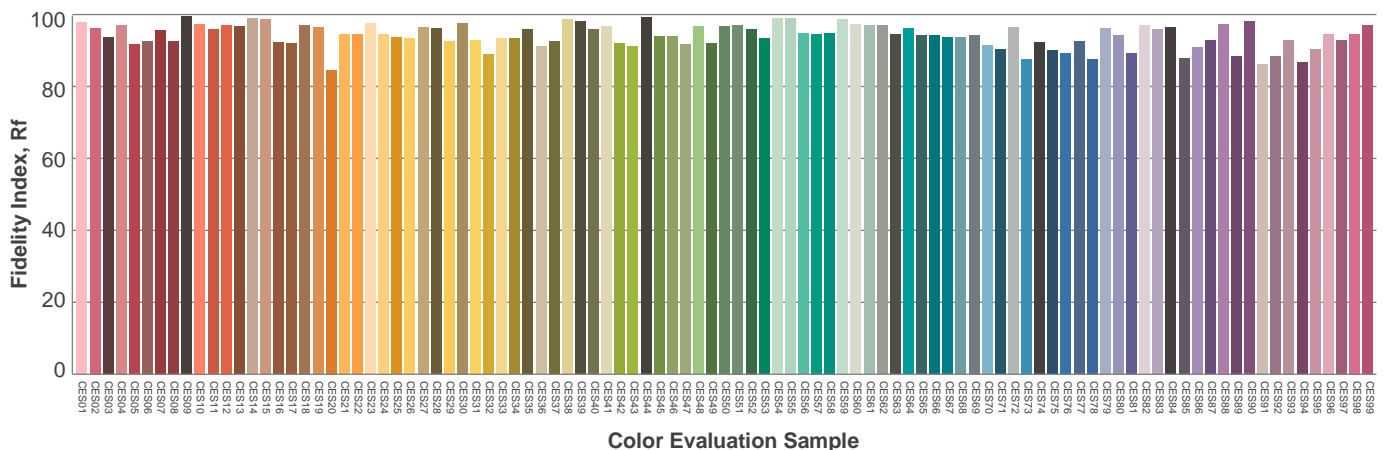
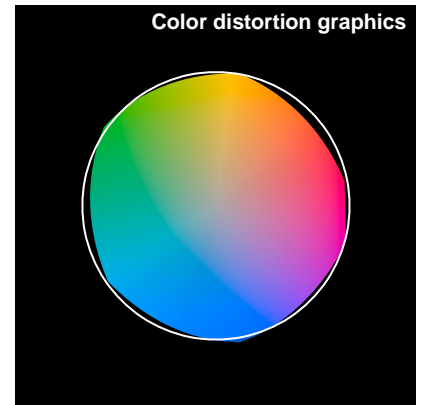
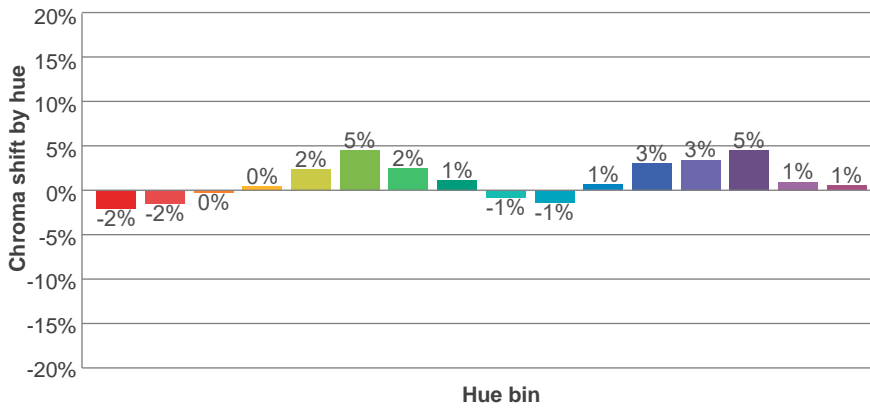
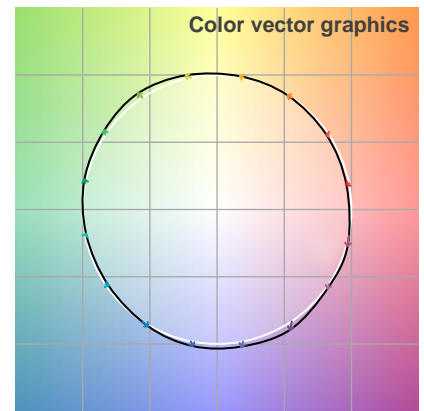
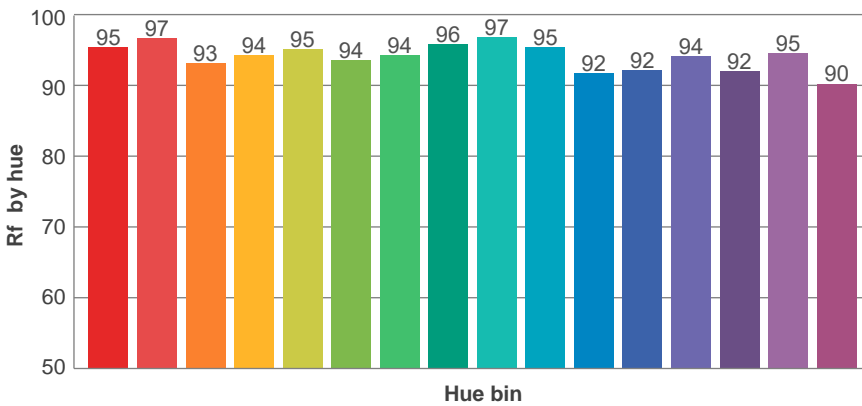
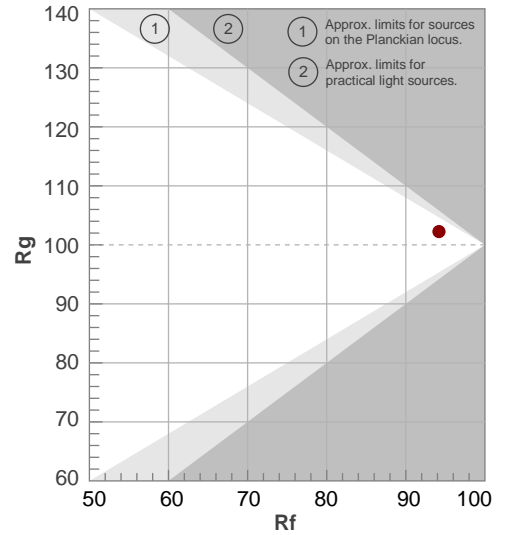

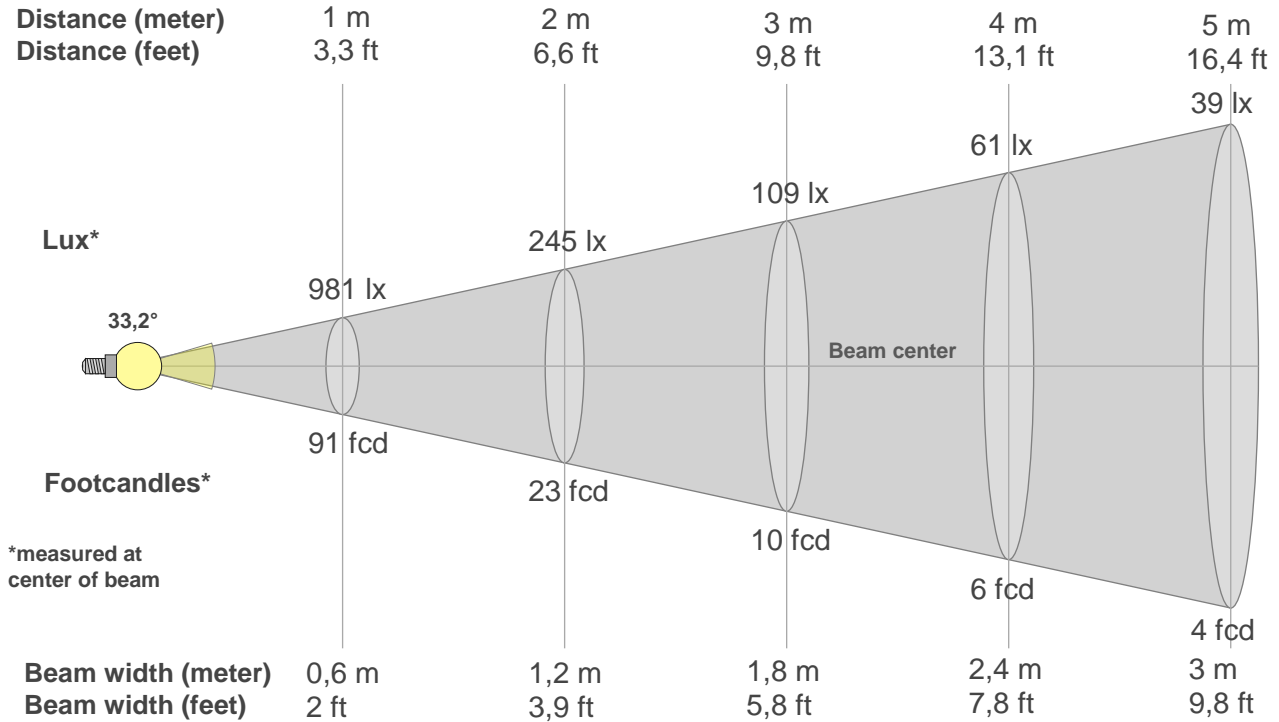

Beam intensities from 1-20m

1m	2m	3m	4m	5m	6m	7m	8m	9m	10m	11m	12m	13m	14m	15m	16m	17m	18m	19m	20m
3,3ft	6,6ft	9,8ft	13,1ft	16,4ft	19,7ft	23ft	26,2ft	29,5ft	32,8ft	36,1ft	39,4ft	42,7ft	45,9ft	49,2ft	52,5ft	55,8ft	59,1ft	62,3ft	65,6ft
981lx	245lx	109lx	61lx	39lx	27lx	20lx	15lx	12lx	10lx	8lx	7lx	6lx	5lx	4lx	4lx	3lx	3lx	3lx	2lx
91,2fcd	22,8fcd	10,1fcd	5,7fcd	3,6fcd	2,5fcd	1,9fcd	1,4fcd	1,1fcd	0,9fcd	0,8fcd	0,6fcd	0,5fcd	0,5fcd	0,4fcd	0,4fcd	0,3fcd	0,3fcd	0,3fcd	0,2fcd

Intensities in 0° c-plane

0°	2°	4°	6°	8°	10°	12°	14°	16°	18°	20°	22°	24°	26°	28°	30°	32°	34°	36°	38°
981	967	939	906	834	762	680	595	513	438	364	307	253	208	173	139	117	95	79	65
100%	99%	96%	92%	85%	78%	69%	61%	52%	45%	37%	31%	26%	21%	18%	14%	12%	10%	8%	7%

Intensities in 90° c-plane

0°	2°	4°	6°	8°	10°	12°	14°	16°	18°	20°	22°	24°	26°	28°	30°	32°	34°	36°	38°
981	967	939	906	834	762	680	595	513	438	364	307	253	208	173	139	117	95	79	65
100%	99%	96%	92%	85%	78%	69%	61%	52%	45%	37%	31%	26%	21%	18%	14%	12%	10%	8%	7%

Intensities in 180° c-plane

0°	2°	4°	6°	8°	10°	12°	14°	16°	18°	20°	22°	24°	26°	28°	30°	32°	34°	36°	38°
981	967	939	906	834	762	680	595	513	438	364	307	253	208	173	139	117	95	79	65
100%	99%	96%	92%	85%	78%	69%	61%	52%	45%	37%	31%	26%	21%	18%	14%	12%	10%	8%	7%

Intensities in 270° c-plane

0°	2°	4°	6°	8°	10°	12°	14°	16°	18°	20°	22°	24°	26°	28°	30°	32°	34°	36°	38°
981	967	939	906	834	762	680	595	513	438	364	307	253	208	173	139	117	95	79	65
100%	99%	96%	92%	85%	78%	69%	61%	52%	45%	37%	31%	26%	21%	18%	14%	12%	10%	8%	7%

Beam angle 50%	Field angle 10%	Cutoff angle 2,5%	Intensity ratio in 120° cone	Intensity ratio in 90° cone
33,2°	67,5°	95,2°	97,7%	93,2%

ISO candela diagram

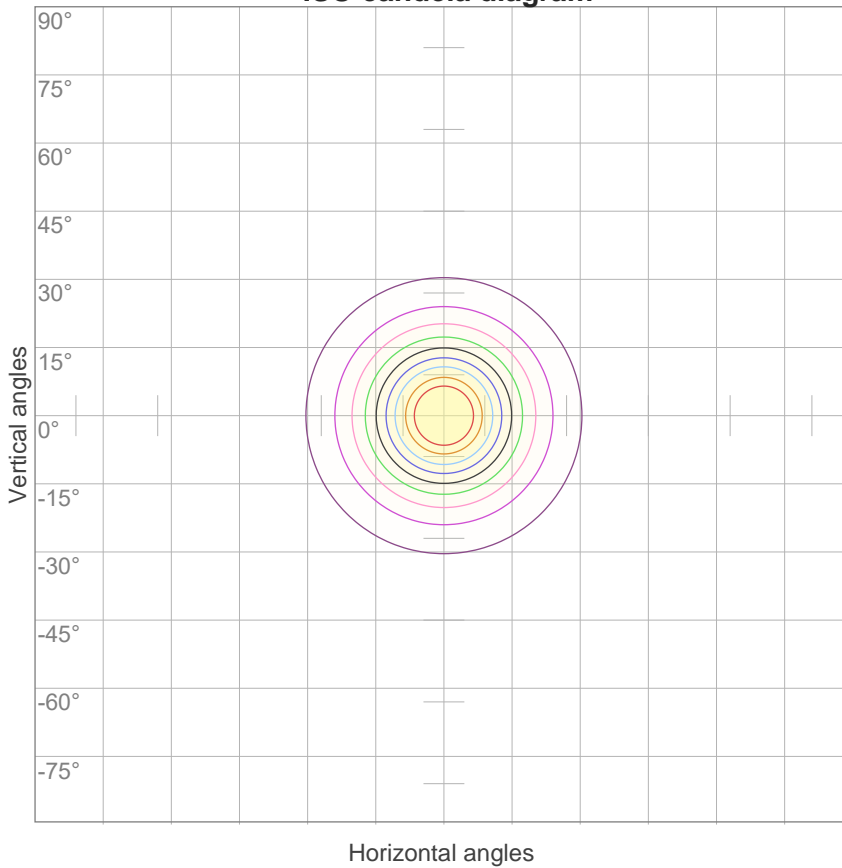

10%	98 cd
20%	196 cd
30%	294 cd
40%	393 cd
50%	491 cd
60%	589 cd
70%	687 cd
80%	785 cd
90%	883 cd

Conditions:

Number of c-planes: 24

Candela at center: 981 cd

ISO lux diagram

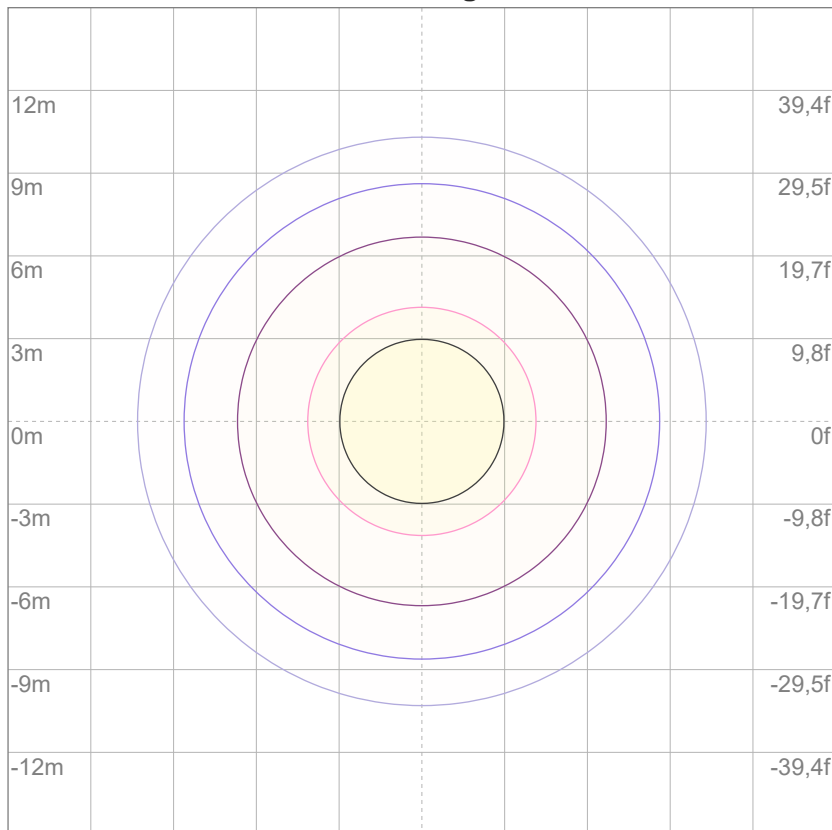

3%	0,294 lx
5%	0,491 lx
10%	0,981 lx
30%	2,94 lx
50%	4,91 lx

Conditions:

Number of c-planes: 24

Lux at center: 9,81 lx

*Lux distribution on a surface
when lamp is mounted at 10
meters from the surface.*

Glare Evaluation According to UGR

p Ceiling		70	70	50	50	30	70	70	50	50	30
p Walls		50	30	50	30	30	50	30	50	30	30
p Floor		20	20	20	20	20	20	20	20	20	20
Room size X Y		Viewing direction at right angles to lamp axis					Viewing direction parallel to lamp axis				
2H	2H	16,3	16,9	16,4	17,1	17,3	16,3	16,9	16,4	17,1	17,3
	3H	16,3	17,0	16,6	17,2	17,4	16,3	17,0	16,6	17,2	17,4
	4H	16,3	17,0	16,7	17,2	17,5	16,3	17,0	16,7	17,2	17,5
	6H	16,4	17,0	16,7	17,3	17,6	16,4	17,0	16,7	17,3	17,6
	8H	16,4	17,0	16,7	17,3	17,7	16,4	17,0	16,7	17,3	17,7
	12H	16,4	16,9	16,7	17,3	17,7	16,4	16,9	16,7	17,3	17,7
4H	2H	16,1	16,8	16,5	17,0	17,3	16,1	16,8	16,5	17,0	17,3
	3H	16,3	16,9	16,7	17,2	17,7	16,3	16,9	16,7	17,2	17,7
	4H	16,4	16,9	16,8	17,3	17,8	16,4	16,9	16,8	17,3	17,8
	6H	16,5	17,0	17,0	17,3	17,7	16,5	17,0	17,0	17,3	17,7
	8H	16,5	17,0	17,0	17,3	17,7	16,5	17,0	17,0	17,3	17,7
	12H	16,5	16,9	17,0	17,3	17,8	16,5	16,9	17,0	17,3	17,8
8H	4H	16,3	16,8	16,8	17,2	17,5	16,3	16,8	16,8	17,2	17,5
	6H	16,5	16,8	17,0	17,3	17,8	16,5	16,8	17,0	17,3	17,8
	8H	16,6	16,9	17,1	17,4	18,0	16,6	16,9	17,1	17,4	18,0
	12H	16,7	16,9	17,3	17,4	18,0	16,7	16,9	17,3	17,4	18,0
12H	4H	16,3	16,7	16,8	17,1	17,6	16,3	16,7	16,8	17,1	17,6
	6H	16,5	16,8	17,0	17,3	17,9	16,5	16,8	17,0	17,3	17,9
	8H	16,6	16,8	17,2	17,3	17,9	16,6	16,8	17,2	17,3	17,9
Variation of the observer position for the luminaire distance S											
S = 1.0H		2,5 / -2,3					2,5 / -2,3				
S = 1.5H		4,6 / -3,2					4,6 / -3,2				
S = 2.0H		6,4 / -3,8					6,4 / -3,8				
Standard table		n/a					n/a				
Correction summand		n/a					n/a				
Corrected glare indices referring to 441 lm total luminous flux											

Coefficients of Utilization

Ceiling reflectance	80				70				50			30			10			0
Wall reflectance	70	50	30	10	70	50	30	10	50	30	10	50	30	10	50	30	10	0
Floor reflectance	20	20	20	20	20	20	20	20	20	20	20	20	20	20	20	20	20	20
RCR	(RCR: Room Cavity Ratio) Room Values are expressed as percentage of Lumens delivered to the task surface																	
0	119	119	119	119	116	116	116	116	111	111	111	106	106	106	102	102	102	100
1	114	111	109	106	111	109	107	105	105	103	101	101	99	98	97	96	95	93
2	108	104	100	97	106	102	98	95	99	96	93	96	93	91	93	91	89	88
3	103	97	93	89	101	96	92	88	93	90	87	91	88	85	88	86	84	82
4	99	92	86	82	97	90	86	82	88	84	81	86	83	80	84	81	79	78
5	94	87	81	77	93	86	81	77	84	79	76	82	78	75	81	77	75	73
6	90	82	76	73	89	81	76	72	80	75	72	78	74	71	77	73	71	69
7	86	78	72	68	85	77	72	68	76	71	68	75	71	68	74	70	67	66
8	83	74	69	65	82	74	68	65	73	68	65	72	67	64	71	67	64	63
9	80	71	65	62	79	70	65	62	69	65	61	68	64	61	68	64	61	60
10	77	68	62	59	76	67	62	59	66	62	59	66	61	58	65	61	58	57

LAMPS (number of lamps)

Luminaire budgetary diagram

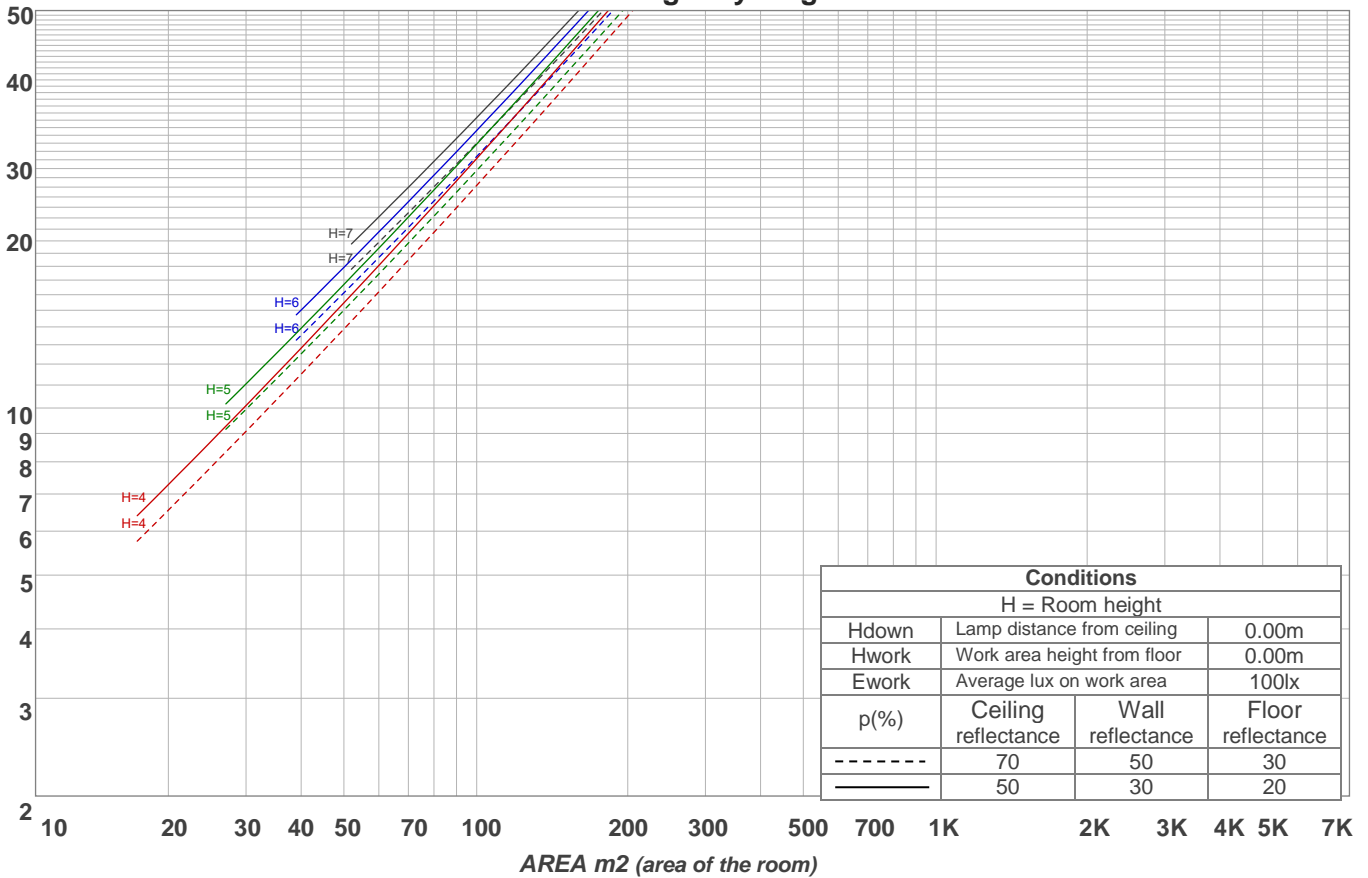

Zonal Lumen Summary

0°-10°	10°-20°	20°-30°	30°-40°	40°-50°	50°-60°	60°-70°	70°-80°	80°-90°
82,5 lm	151 lm	106 lm	55,6 lm	25,5 lm	9,92 lm	4,61 lm	2,35 lm	0,795 lm
90°-100°	100°-110°	110°-120°	120°-130°	130°-140°	140°-150°	150°-160°	160°-170°	170°-180°
0,310 lm	0,334 lm	0,303 lm	0,311 lm	0,276 lm	0,261 lm	0,223 lm	0,136 lm	0,043 lm

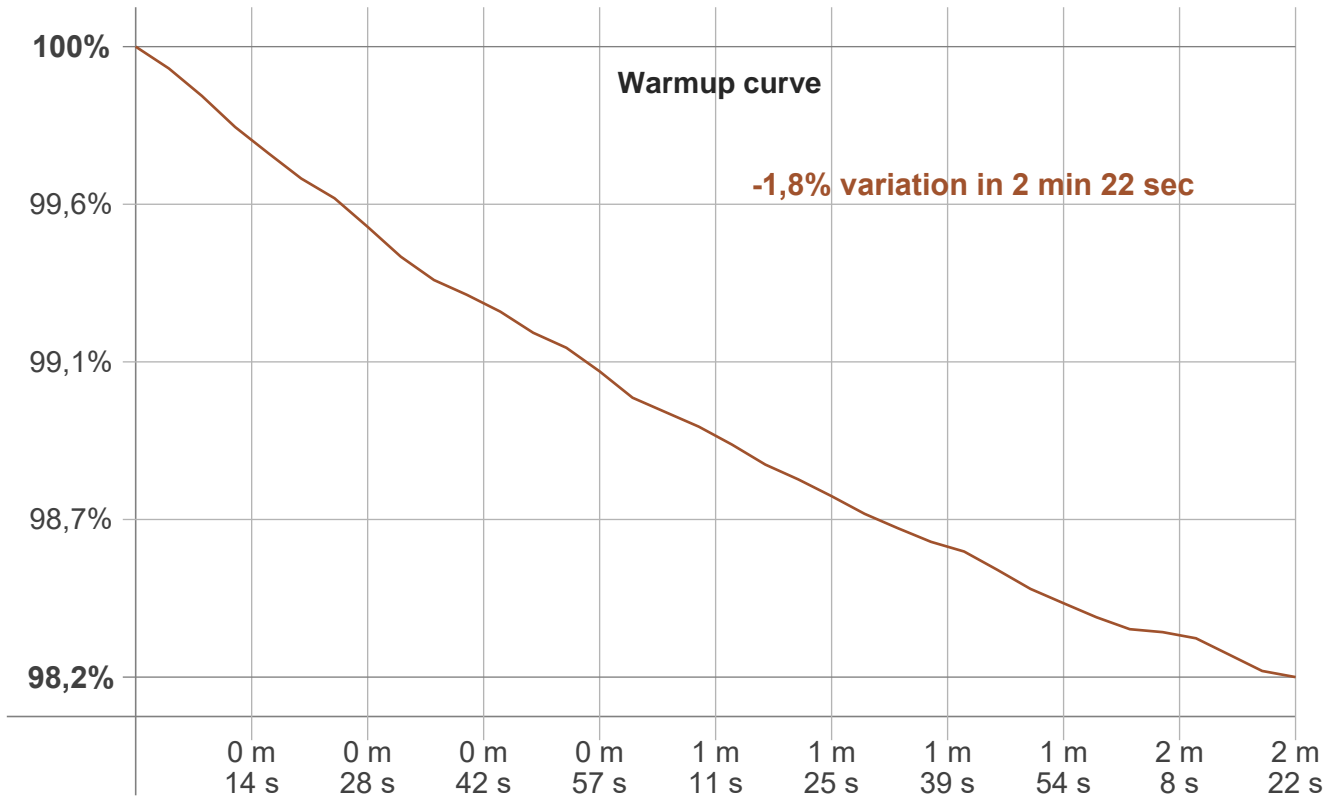

Warmup result

Warmup time:	Not completed
Warmup variation	-1,8%

Warmup conditions

Stable period:	15 min
Stable change max:	2,0%
Minimum time:	15 min

Color temperature change

CCT start	CCT change	CCT end
2632 K	-9 K	2623 K

Output change

Output start	Output change	Output end
448 lm	-7 lm	441 lm

Flicker curve (complete sampled flicker signal)

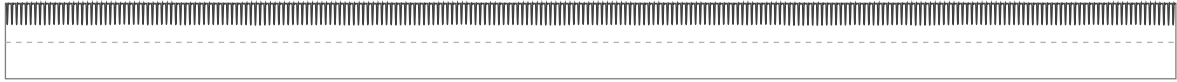

Flicker frame (frame of one flicker period)

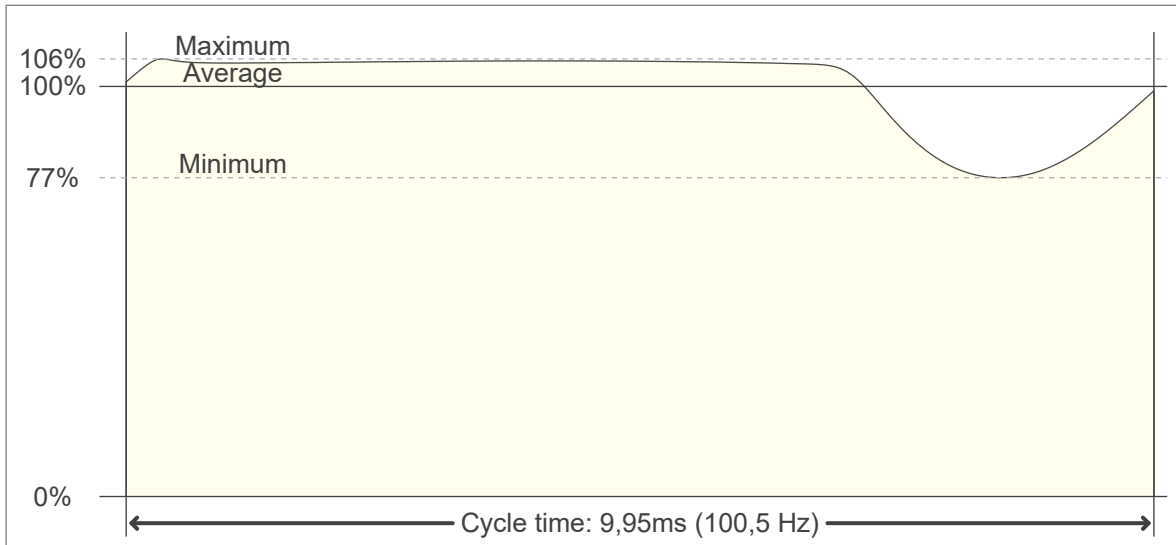

Flicker FFT (frequency scope of flicker curve)

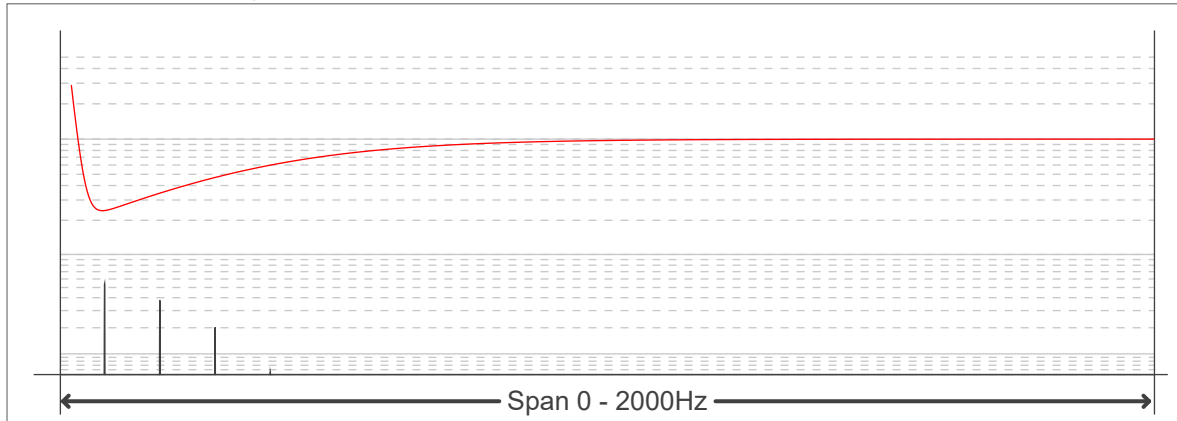

Flicker results

Flicker frequency:	100,5 Hz
Flicker index:	0,04
Flicker percentage:	16,35 %
SVM: (Visual flicker)	0,43
Flicker PstLM value:	0,29

Flicker conditions:

Sample rate:	20000 samples/s
---------------------	------------------------