

**GEBRAUCHSANLEITUNG**

**INSTRUCTIONS**

**INSTRUCTIONS**

**INSTRUCCIONES**

**ISTRUZIONI**

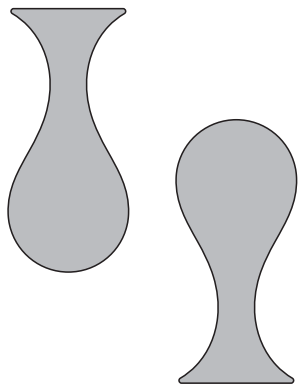

**next**<sup>®</sup>

*less'n'more GmbH*  
*Scheidtweilerstrasse 79 D-*  
*50933 Köln*

*Tel.: +49 (0)221-999844-80*  
*Fax: +49 (0)221-999844-88*

*info@less-n-more.com*  
*www.next.design*  
*www.less-n-more.com*

**Drop\_1 small, Drop\_4 small**

CE □ ▽ IP20 E14 max. 33W



**LEBENSGEFAHR!** Stromkreis abschalten und gegen Wiedereinschalten sichern! **SICHERHEITSHINWEISE** beachten!

**DANGER TO LIFE!** Disconnect power supply and secure it against inadvertent reconnection! Observe **SAFETY INSTRUCTIONS!**

**RISQUE DE MORT!** Couper le circuit de courant et bloquer contre la remise en marche! Respecter les **NOTICES DE SÉCURITÉ!**

**PELIGRO DE MUERTE!** Desconectar el circuito eléctrico y asegurarlo contra una nueva conexión! Observar las **INDICACIONES DE SEGURIDAD!**

**PERICOLO DI MORTE!** Disinserire l'alimentazione elettrica e assicurare contro la riaccensione! Osservare le **INDICAZIONI DI SICUREZZA!**



Drop\_1 small

1

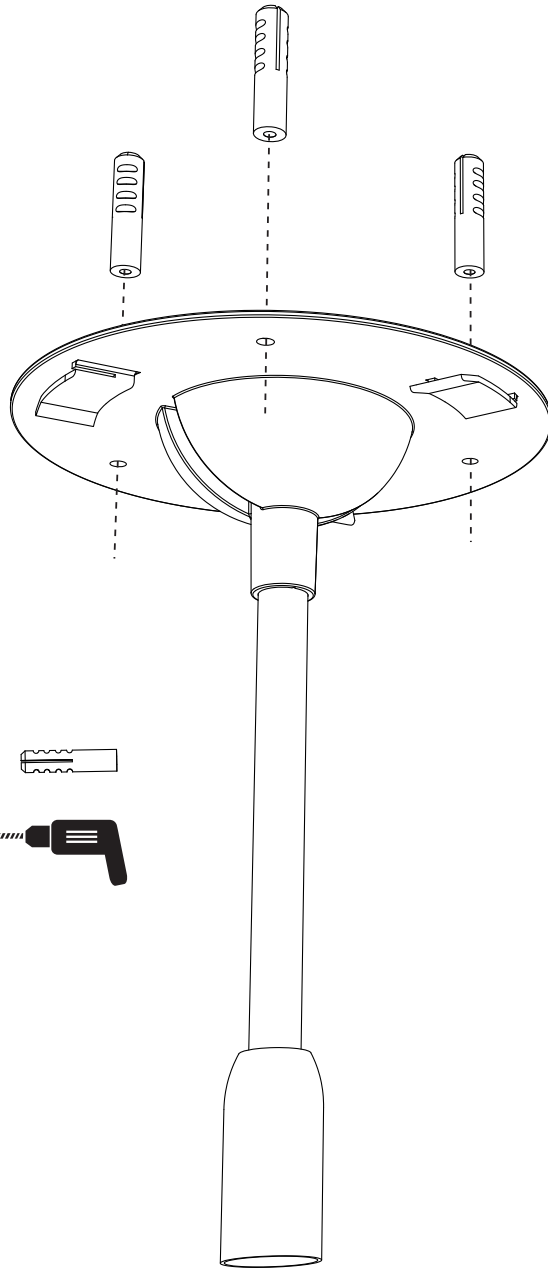

3 x



2

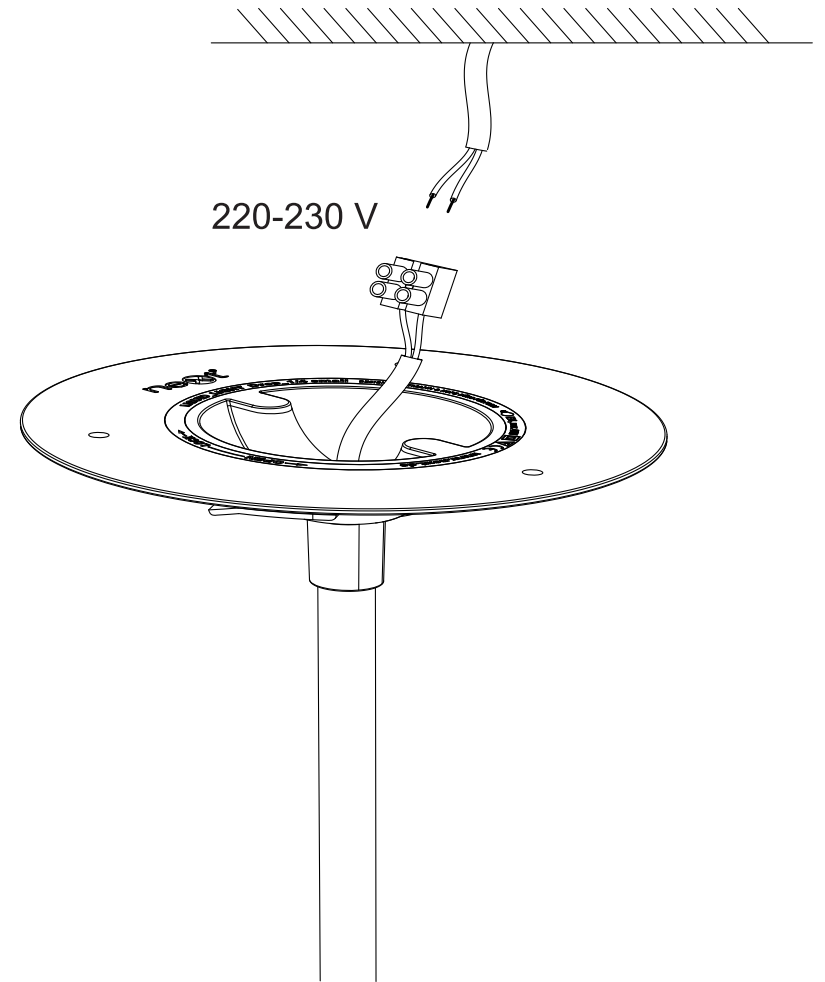

220-230 V

**3**

3 x 

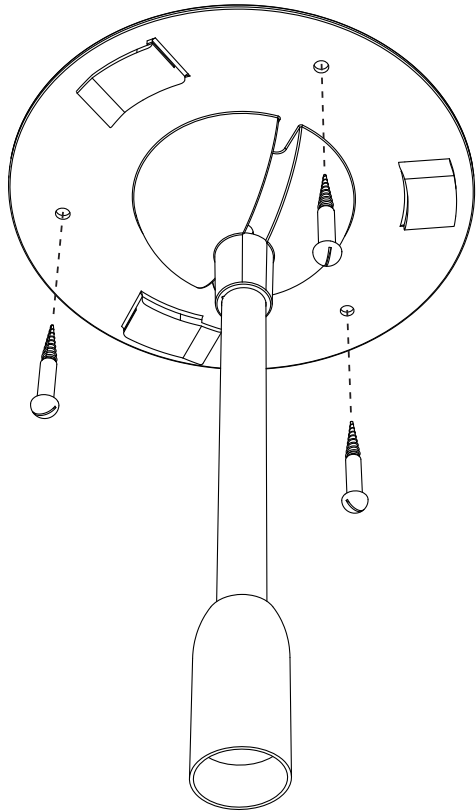

**4**

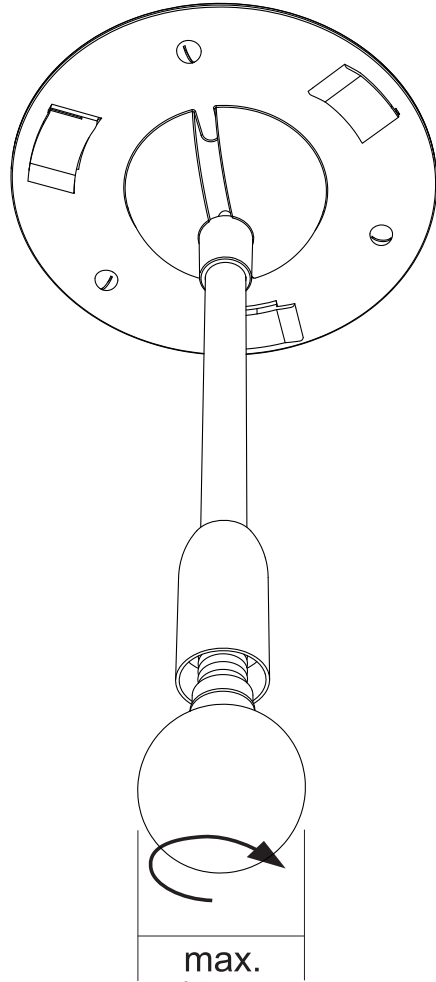

**5**

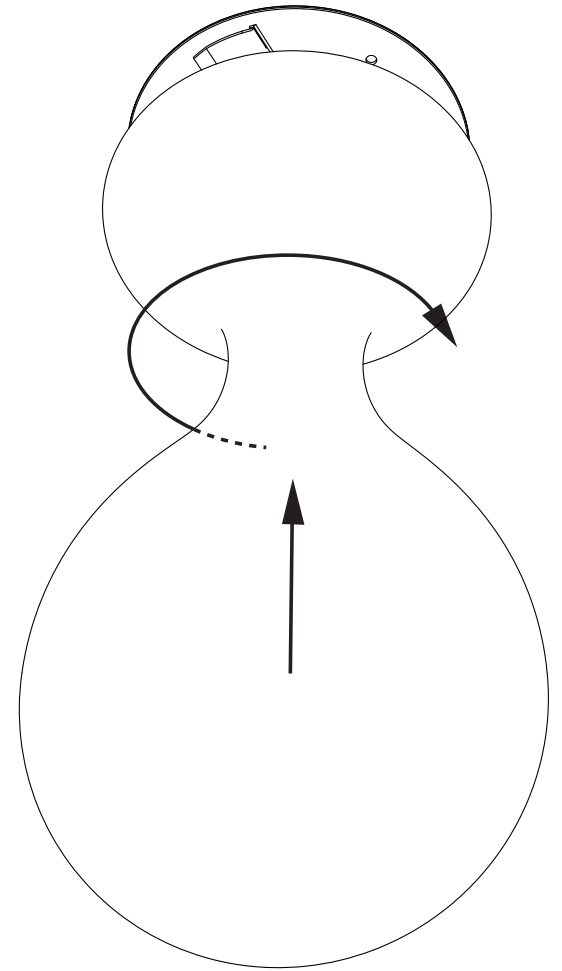

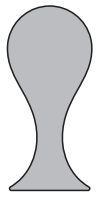

**Drop\_4 small**

**1**

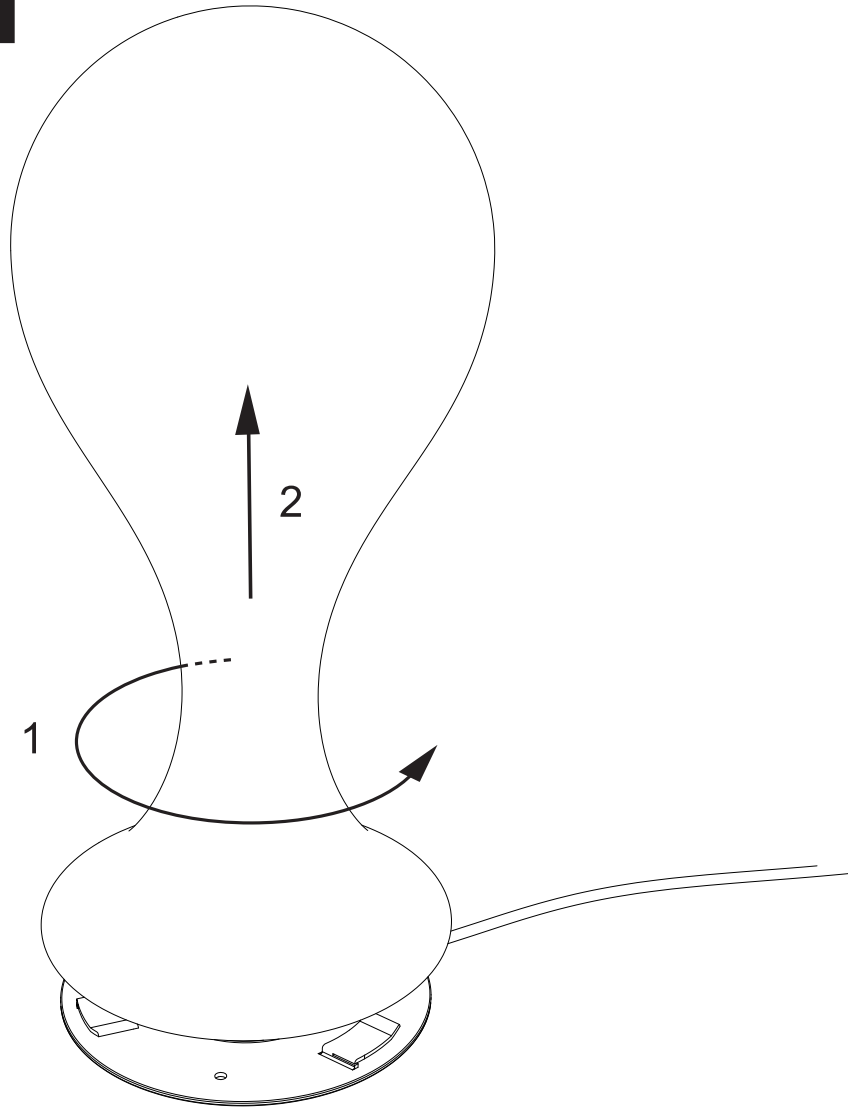

**2**

