

9956151

45W LED / 50W Total
incl. LED Board: L9002418
230V ~ 50Hz

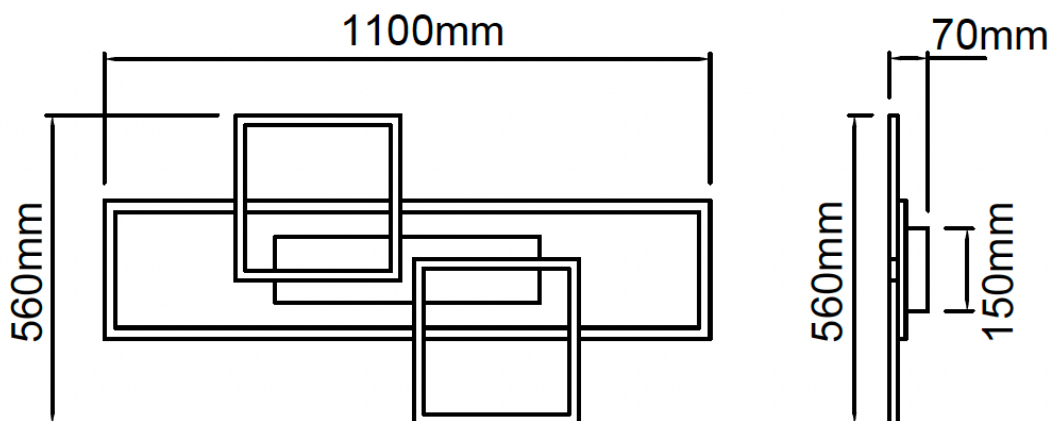

(DE) Bestimmungsgemäße Verwendung

(EN) Intended use | (FR) Utilisation conforme | (NL) Beoogd gebruik | (PL) Stosowanie zgodnie z przeznaczeniem | (NO) Riktig bruk | (DK) Korrekt brug
(SE) Avsedd användning | (FI) Määräystenmukainen käyttö | (IT) Impiego appropriato | (ES) Uso prescrito | (CZ) Použití v souladu s určením
(PT) Utilização correta | (GR) Ενδεδειγμένη χρήση | (SK) Predpokladané použitie | (EE) Eeldatav kasutus | (LV) Paredzams lietojums
(LT) Numatomas naudojimas | (RO) Utilizare intenționată | (SI) Predvidena uporaba | (HR) Namjenska upotreba | (HU) Tervezett felhasználás
(BG) предназначена употреба | (AL) Përdorimi i parashikuar | (MK) Предвидена употреба | (TR) Amaçlı kullanım | (UK) Призначене використання
(BA,ME,RS) Namjenska upotreba

(DE) Ortsfeste Verwendung als Deckenleuchte im Innenbereich	(GB) Provided for stationary indoor use on ceilings
(FR) Installation fixe en tant que plafonnier à l'intérieur	(NL) Vast gebruik als plafondlamp binnenshuis
(PL) Do montażu stacjonarnego jako lampa sufitowa do wnętrz	(NO) Til stasjonært bruk som taklampe innendørs
(DK) Til stationær brug som loftlampe indendørs	(SE) Används som fast taklampe inomhus
(FI) Kiinteä käyttö sisätilojen kattovalaisimena	(IT) Impiego fisso come plafoniera in ambienti interni
(ES) Empleo fijo como lámpara de techo en interiores	(CZ) Stacionární použití jako stropní svítidlo v interiéru
(PT) Aplicação fixa como luminária de teto em interiores	(GR) Σταθερή χρήση ως φωτιστικό οροφής σε εσωτερικό χώρο
(SK) Pevné použitie ako stropné svietidlo v interiéri	(BG) Постоянна употреба като таванно осветително тяло във вътрешни помещения
(EE) Laepaigaldatava sisevalgusti statsionaarne kasutamise	(LV) Pastāvīga izmantošana kā griestu gaismeklis iekštelpās
(LT) Stacionarus naudojimas kaip lubų šviestuvus viduje	(RO) Utilizare fixă ca plafonieră în interior
(SI) Stalna uporaba kot stropna svetilka v notranjosti	(HR) Stalna upotreba kao stropna svjetiljka u unutrašnjosti
(HU) Állandó használat mint mennyezetre szerelhető belső világítótest	(AL) I ofruar për përdorim të brendshëm të stacionar në tavan
(MK) Обезбедено за стационарна употреба на тавани внатре	(TR) Tavanlarda sabit iç mekan kullanımı için sağlanmış
(UK) Забезпечено для стаціонарного внутрішнього використання на стелях	(BA) Osigurano za stacionarnu unutarnju upotrebu na plafonima
	(ME)
	(RS)

(DE) Lieferumfang		
(EN) Package contents (FR) Contenu de la livraison (NL) Bij de levering inbegrepen (PL) Zakres dostawy (NO) Levering (DK) Leveringsomfang (SE) Leveransomfattning (FI) Toimitussisältö (IT) Fornitura (ES) Volumen de suministro (CZ) Rozsah dodávky (PT) Material fornecido (GR) Παραδοτέος εξοπλισμός (SK) Obsah balenia (EE) Pakendi sisu (LV) Pakas saturs (LT) Pakuotės turinys (RO) Conținutul pachetului (SI) Vsebina paketa (HR) Sadržaj paketa (HU) A csomag tartalma (BG) обхват на доставката (AL) Përmbajtja e dorëzimit (MK) Содржина на испорака (TR) Teslimat içeriği (UK) Зміст доставки (BA,ME,RS) Sadržaj isporuke		
(DE) 1 Deckenleuchte Montagematerial Montageanleitung	(GB) 1 Ceiling lamp Installation hardware Mounting instructions	(FR) 1 Plafonnier Matériel de montage Instructions de montage
(NL) 1 Plafondlamp Monteringsmateriale Montagehandleiding	(PL) 1 Lampa sufitowa Elementy montażowe Instrukcja montażu	(NO) 1 Taklampe Monteringsmateriale Brukerveiledning
(DK) 1 Loftlampe Monteringsmateriale Brugervejledning	(SE) 1 Taklampa Monteringsmaterial Monteringsanvisning	(FI) 1 Kattovalaisin Asennus materiaali Asennusohjeet
(IT) 1 Plafoniera Materiale di montaggio Istruzioni di montaggio	(ES) 1 Lámpara de techo Material de montaje Instrucciones de montaje	(CZ) 1 Stropní svítidlo Materiál pro montáž Návod k montáži
(PT) 1 Luminária de teto Material de montagem Instruções de montagem	(GR) 1 Φωτιστικό οροφής Υλικό συναρμολόγησης Οδηγίες συναρμολόγησης	(SK) 1 stropné svietidlo Inštalacný hardvér Inštalčná príručka
(BG) 1 таванно осветително тяло материали за монтаж инструкции за монтаж	(EE) 1 laevalgusti Paigaldustarvikud Paigaldusjuhend	(LV) 1 griestu gaismeklīs Instalācijas aparātūra Uzstādīšanas instrukcija
(LT) 1 lubų šviestuvai Montavimo aparatinė įranga Montavimo instrukcija	(RO) 1 plafonieră Hardware de instalare Instrucțiuni de montare	(SI) 1 stropna svetilka Namestitvena strojna oprema Navodila za montažo
(HR) 1 stropna svjetiljka Instalacijski hardver Upute za montažu	(HU) 1 mennyezeti világítótest Telepítési hardver Szerelési útmutató	(AL) 1 Lampa tavan Materiali i montimit Udhëzuesi i montimit
(MK) 1 Плафонска лампа Монтажен материјал Упатство за монтажа	(TR) 1 Tavan lambası Montaj malzemesi Montaj kılavuzu	(UK) 1 Світильник на стелі Монтажний матеріал Інструкція з монтажу
(BA) 1 Plafonska lampa (ME) Montažni materijal (RS) Uputstvo za montažu		

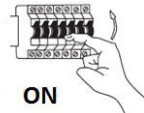
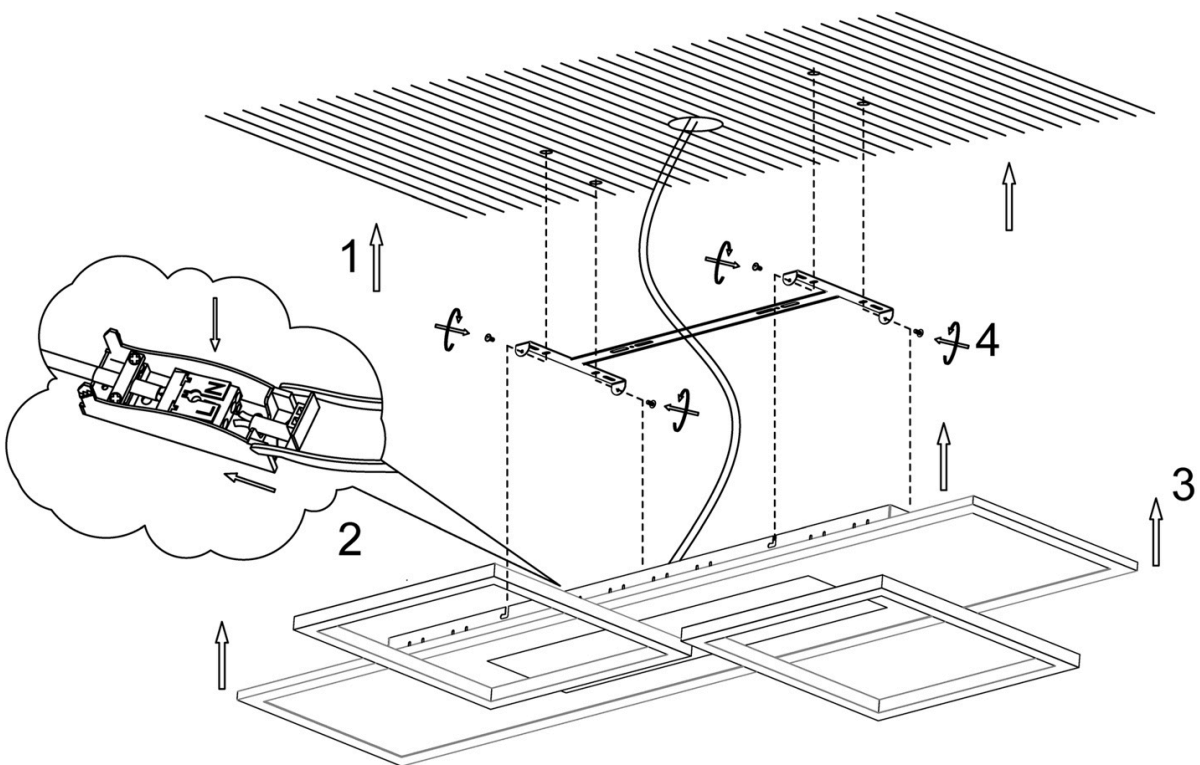
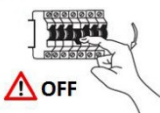

Fernbedienung/ remote control/ Télécommande

1	AUS (Haupt- und Nebenlicht)
2	AN (Haupt- und Nebenlicht) Codierung der Fernbedienung: Schalten Sie die Leuchte ein und halten Sie die Taste innerhalb von 6 Sekunden gedrückt. Das Licht flackert 1x wenn die Codierung erfolgreich war
3	Helligkeit +
4	
5	CCT 2700K-6500K
6	Farbtemperatur wechseln im folgenden Zyklus: (1) 4000K 100% (Haupt- und Nebenlicht) (2) 2700K 100% (Haupt- und Nebenlicht) (3) 6500K 100% (Haupt- und Nebenlicht) (4) 6500K 100% Hauptlicht + 2700K 100% Nebenlicht (5) 2700K 100% Hauptlicht + 6500K 100% Nebenlicht (6) Hauptlicht AUS + 2700K 100% Nebenlicht (7) 6500K 100% Hauptlicht + Nebenlicht AUS (8) Nachtlicht 4000K 10% (Haupt- und Nebenlicht)
7	Helligkeit -
8	Nachtlicht 4000K 10% (Haupt- und Nebenlicht) (Farbtemperatur kann durch drücken der Tasten 4 und 5 reguliert werden)
9	Drücken Sie die Taste bei eingeschaltetem Haupt- und Nebenlicht, um das Hauptlicht individuell zu steuern (CCT und Helligkeit). Taste zwei Sekunden gedrückt halten: Hauptlicht kann an- und ausgeschaltet werden
10	Drücken Sie die Taste bei eingeschaltetem Haupt- und Nebenlicht, um das Nebenlicht individuell zu steuern (CCT und Helligkeit). Taste zwei Sekunden gedrückt halten: Nebenlicht kann an- und ausgeschaltet werden

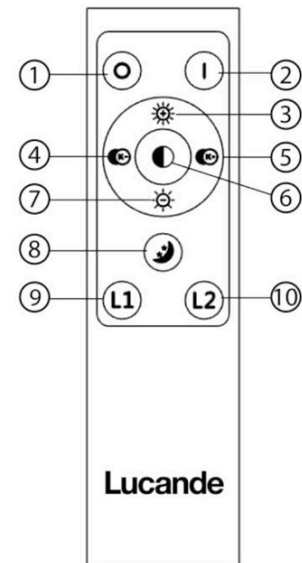

1	OFF (main and subsidiary light)
2	ON (main and subsidiary light) Matching code: power on the lamp and press long the button within 6 seconds. The lamp will flicker once if the matching is successful
3	Brightness +
4	
5	CCT 2700K-6500K
6	CCT change cycle: (1) 4000K 100% (main and subsidiary light) (2) 2700K 100% (main and subsidiary light) (3) 6500K 100% (main and subsidiary light) (4) 6500K 100% main light + 2700K 100% subsidiary light (5) 2700K 100% main light + 6500K 100% subsidiary light (6) Main light OFF + 2700K 100% subsidiary light (7) 6500K 100% main light + subsidiary light OFF (8) Night light 4000K 10% (main and subsidiary light)
7	Brightness -
8	Night light 4000K 10% (main and subsidiary light) (color temperature can be regulated by pressing buttons 4 and 5)
9	1. When main light and subsidiary light are on, press the button to choose "main light" for individually control its CCT and brightness. 2. Long press the button for 2 seconds, turn off the main light. Press the button again, turn on the main light.
10	1. When main light and subsidiary light are on, press the button to choose "Subsidiary light" for individually control its CCT and brightness. 2. Long press the button for 2 seconds, turn off the subsidiary light. Press the button again, turn on the subsidiary light.

1	ARRÊT (lumière principale et secondaire)
2	MARCHE (lumière principale et secondaire) Codage de la télécommande: Allumez la lumière et appuyez sur le bouton dans les 6 secondes. La lumière clignote 1x si le codage a réussi.
3	luminosité +
4	
5	CCT 2700K-6500K
6	Changement de CCT dans le cycle suivant: (1) 4000K 100% (lumière principale et secondaire) (2) 2700K 100% (lumière principale et secondaire) (3) 6500K 100% (lumière principale et secondaire) (4) 6500K 100% lumière principale + 2700K 100% lumière secondaire (5) 2700K 100% lumière principale + 6500K 100% lumière secondaire (6) Éclairage principal éteint + 2700K 100% lumière secondaire (7) 6500K 100% lumière principale + lumière secondaire OFF (8) Veilleuse 4000K 10% (lumière principale et secondaire)
7	luminosité -
8	Veilleuse 4000K 10% (lumière principal et secondaire) (CCT peut être réglé en appuyant sur les boutons 4 et 5)
9	Lorsque l'éclairage principal et secondaire est allumé, appuyez sur le bouton pour contrôler individuellement l'éclairage principal (CCT et luminosité). Maintenez le bouton enfoncé pendant deux secondes: l'éclairage principal peut être allumé et éteint
10	Lorsque l'éclairage principal et secondaire est allumé, appuyez sur le bouton pour contrôler individuellement l'éclairage secondaire (CCT et luminosité). Maintenez le bouton enfoncé pendant deux secondes: l'éclairage secondaire peut être allumé et éteint

Funktion mit dem Wandschalter:

CCT Modus: Schalten Sie die Leuchte über den Wandschalter ein und innerhalb von 5 Sekunden wieder aus. Innerhalb von 3 Sekunden Leuchte wieder einschalten. CCT Modus ist aktiviert. Durch weiteres Betätigen des Wandschalters lassen sich folgende Varianten wählen:

1. 4000K Haupt- und Nebenlicht
2. 2700K Haupt- und Nebenlicht
3. 6500K Haupt- und Nebenlicht
4. 6500K Hauptlicht + 2700K Nebenlicht
5. 2700K Hauptlicht + 6500K Nebenlicht

Memory-Funktion: Ist die Leuchte länger als 10 Sekunden eingeschaltet und dann länger als 5 Sekunden ausgeschaltet, wird beim erneuten Einschalten die zuletzt genutzte Lichtszene eingestellt.

Wall switch function:

CCT mode: Turn the light on via the wall switch and turn off again within 5 seconds. Turn on the light again within 3 seconds. CCT mode is activated. The following variants can be selected by pressing the wall switch again:

1. 4000K main and subsidiary light
2. 2700K main and subsidiary light
3. 6500K main and subsidiary light
4. 6500K main light + 2700K subsidiary light
5. 2700K main light + 6500K subsidiary light

Memory function: If the light is switched on for more than 10 seconds and then switched off for more than 5 seconds, the light scene last used is set when it is switched on again.

Fonction avec l'interrupteur mural :

Mode CCT: allumez la lumière à l'aide de l'interrupteur mural et éteignez-la à nouveau dans les 5 secondes. Allumez la lumière dans les 3 secondes. Le mode CCT est activé. Les variantes suivantes peuvent être sélectionnées en appuyant à nouveau sur l'interrupteur mural:

1. Lumière principale et secondaire de 4000K
2. Lumière principale et secondaire de 2700K
3. Lumière principale et secondaire de 6500K
4. Lumière principale 6500K + lumière secondaire 2700K
5. Lumière principale 2700K + lumière secondaire 6500K

Fonction mémoire: Si la lumière est allumée pendant plus de 10 secondes puis éteinte pendant plus de 5 secondes, la dernière scène d'éclairage utilisée est définie lors de sa remise en marche.

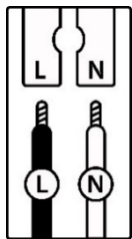

	(DE)	(EN)	(FR)	(NL)	(PL)	(NO)
L	Stromführender Leiter	Live conductor	Conducteur	Spanningvoerende draad	Przewód prądowy	Strømførende leder
N	Neutralleiter	Neutral conductor	Conducteur neutre	Nulleider	Przewód zerowy	Nøytralleider

	(DK)	(SE)	(FI)	(IT)	(ES)	(CZ)
L	Strømførende leder	Strömförande ledare	Virtajohdin	Conduttore sotto tensione	Conductor de corriente	Vodič pod napětím
N	Neutralleider	Neutralledare	Nollajohdin	Conduttore neutro	Conductor neutro	Neutrální vodič

	(PT)	(GR)	(SK)	(EE)	(LV)	(LT)
L	Condutor vivo	Ρευματοφόρος αγωγός	Živý vodič	Faasisjuht	Dzīvais vadītājs	Gyvas dirigentas
N	Condutor neutro	Ουδέτερος αγωγός	Neutrálny vodič	Neutraaljuht	Neitrālais vadītājs	Neutrinis dirigentas

	(RO)	(SI)	(HR)	(HU)	(BG)	(AL)
L	Conductor viu	Živi dirigent	Živi dirigent	Élő vezető	проводник под напряжение	Konduktor i gjallë
N	Conductor neutru	Nevtralni dirigent	Neutralni dirigent	Semleges vezető	нулев проводник	Konduktor neutral

	(MK)	(TR)	(UK)	(BA)(ME)(RS)
L	Жив кондуктор	Canlı yönetici	Живий диригент	Živi dirigent
N	Неутрален проводник	Nötr iletken	Нейтральний провідник	Neutralni provodnik

(DE) Verwendete Symbole

(EN) Safety Precautions | (FR) Symboles utilisés | (NL) Gebruikte symbolen | (PL) Stosowane symbole | (NO) Brukte symboler | (DK) Brugte symboler | (SE) Använda symboler | (FI) Käytetyt symbolit | (IT) Simboli usati | (ES) Símbolos empleados | (CZ) Použité symboly | (PT) Símbolos utilizados | (GR) Χρησιμοποιούμενα σύμβολα | (SK) Bezpečnostné opatrenia | (EE) Ohutusabinõud | (LV) Drošības pasākumi | (LT) Saugos priemonės | (RO) Măsuri de precauție | (SI) Varnostni ukrepi | (HR) Mjere opreza | (HU) Használt szimbólumok | (BG) Мерки за безопасност | (AL) Simbolet e përdorura | (MK) Користени симболи | (TR) Kullanılan semboller | (UK) Використовувані символи | (BA,ME,RS) Korišteni simboli

IP 20

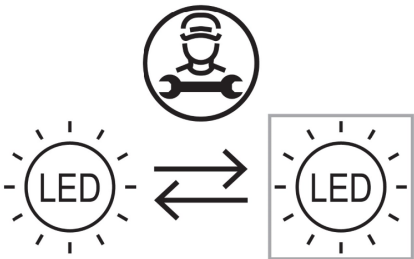

<p>(DE) Dieses Produkt enthält eine Lichtquelle der Energieeffizienzklasse E (EN) This product contains a light source of energy efficiency class E (FR) Ce produit comprend une source de lumière de classe d'efficacité énergétique E (NL) Dit product bevat een lichtbron van energie-efficiëntieklasse E (PL) Produkt ten zawiera źródło światła o klasie efektywności energetycznej E (NO) Dette produktet inneholder en lyskilde i energieeffektivitetsklasse E (DK) Dette produkt indeholder en lyskilde af energieeffektklasse E (SE) Denna produkt innehåller en ljuskälla i energieffektivitetsklass E (FI) Tämä tuote sisältää energiatehokkuusluokan E valonlähteen (IT) Questo prodotto contiene una sorgente luminosa della classe di efficienza energetica E (ES) Este producto contiene una fuente de luz de la clase de eficiencia energética E (CZ) Tento výrobek obsahuje světelný zdroj třídy energetické účinnosti E (PT) Este produto contém uma fonte de luz da classe de eficiência energética E (GR) Αυτό το προϊόν περιέχει μια φωτεινή πηγή ενεργειακής απόδοσης κλάσης E (SK) Tento výrobok obsahuje zdroj svetla triedy energetickej efektivity E (EE) See toode sisaldab energiatõhususklassi E valgusallikat (LV) Šis produkts satur enerģijas efektivitātes klases E gaismas avotu (LT) Šis gaminys turi energijos efektyvumo klasės E šviesos šaltinį (RO) Acest produs conține o sursă de lumină de clasă de eficiență energetică E (SI) Ta izdelek vsebuje svetlobni vir energijskega razreda E (HR) Ovaj proizvod sadrži izvor svjetlosti energetske učinkovitosti klase E (HU) Ez a termék egy E energiahatékonysági osztályú fényforrást tartalmaz (BG) Този продукт съдържа източник на светлина с клас на енергийна ефективност: E (AL) Ky produkt përmban një burim drite të klasës së efikasitetit të energjisë E (MK) Овој производ содржи извор на светлина од класа на енергетска ефикасност E (TR) Bu ürün, enerji verimliliği sınıfı E olan bir ışık kaynağı içerir (UK) Цей продукт містить джерело світла класу енергоефективності E (BA)(ME)(RS) Ovaj proizvod sadrži izvor svjetlosti energetske klase E</p>	<p>QR</p> 	<p>EAN</p> <p>4251911752885</p>
--	--	---------------------------------

	<p>(DE) Durch einen Fachmann austauschbare Lichtquelle (nur LED). (EN) Replaceable (LED only) light source by a professional. (FR) Source de lumière remplaçable (LED uniquement) par un professionnel. (NL) Lichtbron (alleen led) te vervangen door een professional. (PL) Wymienne (tylko LED) źródło światła wykonane przez profesjonalistę. (NO) Utskiftbar (kun LED) lyskilde av en profesjonell. (DK) Udskiftelig lyskilde (kun LED), udskiftes af en elektriker. (SE) Ljuskälla (endast LED) utbytbar genom fackman. (FI) Ammattilainen voi vaihtaa vaihdettavan (vain LED) valonlähteen. (IT) Sorgente luminosa (solo LED) sostituibile da un professionista. (ES) Fuente de luz (solo LED) sustituible por un profesional. (CZ) Vyměnitelný (pouze LED) světelný zdroj odborníkem. (PT) Luz LED (apenas LED) substituível por um profissional. (GR) Η πηγή φωτός (μόνο LED) να αντικαθίσταται από επαγγελματία. (SK) Zdroj svetla (iba LED) vymeniteľný prostredníctvom odborníka. (EE) Spetsialisti poolt vahetatav valgusallikas (ainult LED). (LV) Speciālista maināms gaismas avots (tikai LED). (LT) Specialisto keičiamas šviesos šaltinis (tik LED). (RO) Sursă de lumină schimbabilă de către un specialist (doar LED). (SI) Svetlobni vir, ki ga lahko zamenja strokovnjak (samo LED). (HR) Izvor svjetlosti koji može zamijeniti stručnjak (samo LED). (HU) Szakember által cserélhető (csak LED) fényforrás. (BG) Светлинен източник, който може да се смени от специалист (само LED). (AL) Burim drite i zëvendësueshëm (LED vetëm) nga një profesionist. (MK) Изворот на светлина (само LED) се заменува од професионалец. (TR) Değiştirilebilir (yalnızca LED) ışık kaynağı bir profesyonel tarafından değiştirilir. (UK) Замінний (тільки LED) джерело світла замінюється фахівцем. (BA)(ME)(RS) Zamjenjiv (samo LED) izvor svjetlosti zamjenjuje profesionalac.</p>
---	--

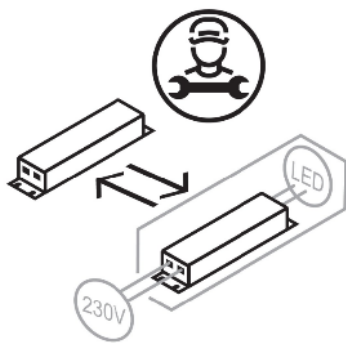

- (DE) Durch einen Fachmann austauschbares Betriebsgerät.
 (EN) Replaceable control gear by a professional.
 (FR) Contrôleur remplaçable par un professionnel.
 (NL) Voorschakelapparatuur te vervangen door een professional.
 (PL) Wymienny układ sterujący przez profesjonalistę.
 (NO) Utskiftbar kontrollutstyr av en profesjonell.
 (DK) Udskiftelig igangsætter, udskiftes af en elektriker.
 (SE) Styrdon utbytbar genom fackman.
 (FI) Ammattilainen voi vaihtaa vaihdettavat ohjauslaitteet.
 (IT) Dispositivo di controllo sostituibile da un professionista.
 (ES) Dispositivo de control sustituible por un profesional.
 (CZ) Vyměnitelný předřadník odborníkem.
 (PT) Dispositivo de controlo substituível por um profissional.
 (GR) Ο εξοπλισμός ελέγχου να αντικαθίσταται από επαγγελματία.
 (SK) Predradník vymeniteľný prostredníctvom odborníka.
 (EE) Spetsialisti poolt vahetatah juhtseade.
 (LV) Speciālista maināma vadības iekārta.
 (LT) Specialisto keičiamas valdymo įrenginys.
 (RO) Aparat de comandă schimbabil de către un specialist.
 (SI) Nadomestna krmilna naprava, ki jo lahko zamenja strokovnjak.
 (HR) Zamjenjivi upravljački sklop koji može zamijeniti stručnjak.
 (HU) Szakember által cserélhető vezérlőszerkezet.
 (BG) Уред, който може да се смени от специалист.
 (AL) Pajisje kontrolli e zëvendësueshme nga një profesionist.
 (MK) Заменлива контролна опрема од страна на професионалец.
 (TR) Profesyonel tarafından değiştirilebilir kontrol donanımı.
 (UK) Замінний контрольний пристрій фахівцем.
 (BA)(ME)(RS) Zamjenjiva kontrolna oprema od strane profesionalca.