

Anish, Playing Spoons.

design Dodo Arslan
terzani.com

TERZANI
LA LUCE PENSATA



Type |
Suspension

Materials |
Brass

Finishes | Code

 Nickel
0Q61S E7 C8

 Gold leaf
0Q61S H5 C8

Body |

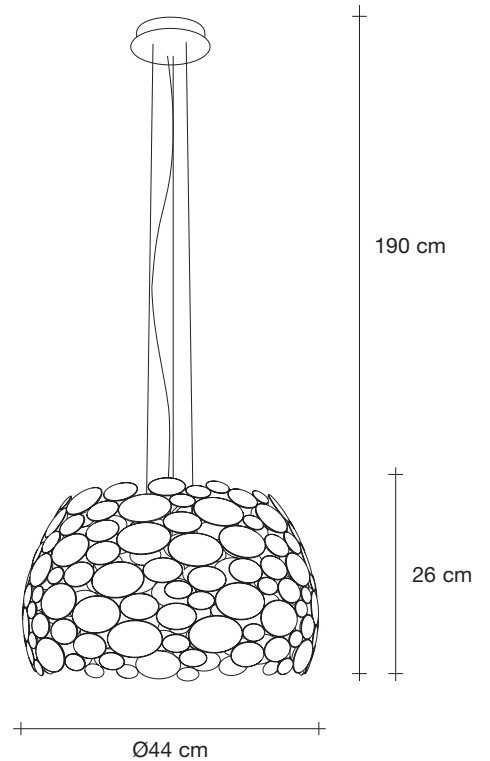

Canopy |

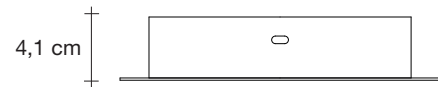

Integrated Led |

100-240V ~ 50/60Hz

 LED integrated
6 x 4,5W 3180 lm 3000K
or optional 2700K

 Dimmable with 1-10V,
PWM, 10-100 Ω
Dali system on request

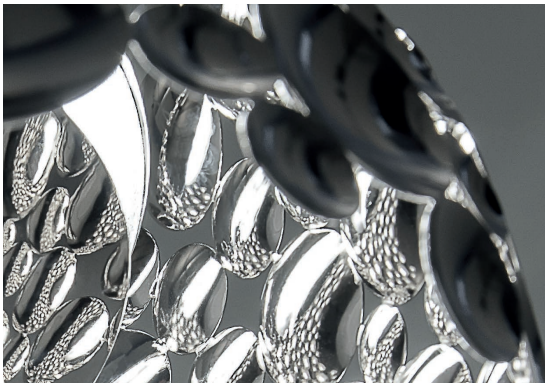

A playful study of reflection, the idea for Anish was born when designer Dodo Arslan, while playing with his daughter, became fascinated by the almost infinite reflections spoons unleashed due to their concave and convex surfaces. Taking this idea to a larger scale, Dodo took inspiration from Italian flatware manufacturer Sambonet and created a pendant composed of a range of spoons from the smallest teaspoon to serving spoons which magnifies the reflective quality of this shape. The result is an installation that creates a "galaxy" effect of seemingly endless light. Design Dodo Arslan.

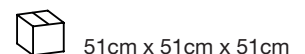
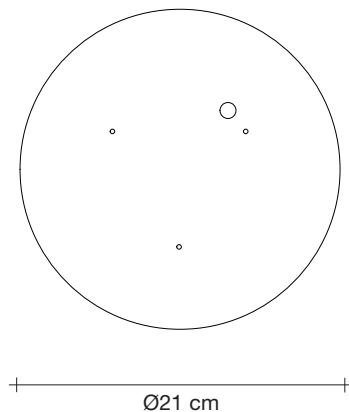

Anish, Playing Spoons.

design Dodo Arslan
terzani.com

TERZANI
LA LUCE PENSATA



Type |
Suspension

Materials |
Brass

Finishes | Code

 Nickel
0Q62S E7 C8

 Gold leaf
0Q62S H5 C8

Body |

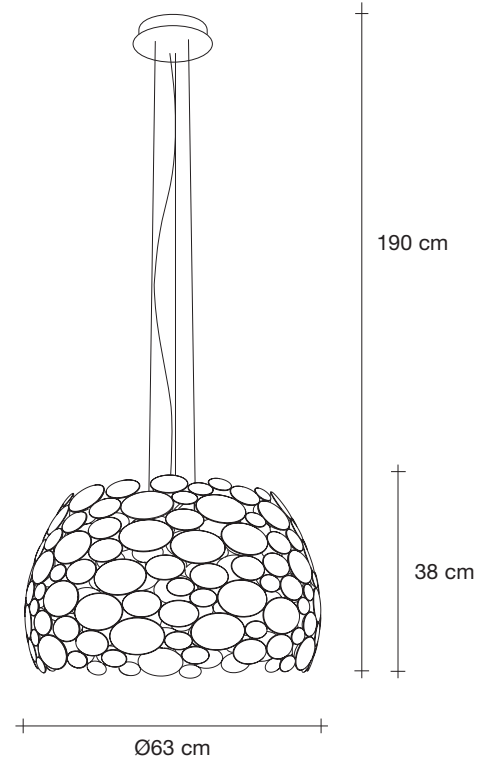

Canopy |



Integrated Led |

100-240V ~ 50/60Hz

 LED integrated
6 x 4,5W 3180 lm 3000K
or optional 2700K

 Dimmable with 1-10V,
PWM, 10-100 Ω
Dali system on request

A playful study of reflection, the idea for Anish was born when designer Dodo Arslan, while playing with his daughter, became fascinated by the almost infinite reflections spoons unleashed due to their concave and convex surfaces. Taking this idea to a larger scale, Dodo took inspiration from Italian flatware manufacturer Sambonet and created a pendant composed of a range of spoons from the smallest teaspoon to serving spoons which magnifies the reflective quality of this shape. The result is an installation that creates a "galaxy" effect of seemingly endless light. Design Dodo Arslan.

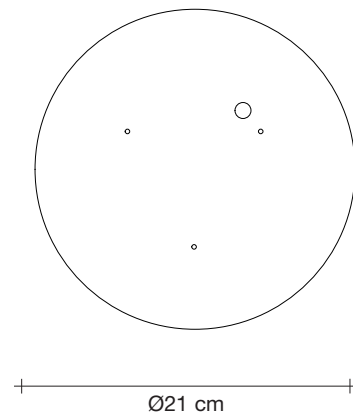

14,5



9



76cm x 76cm x 60cm

Anish, Playing Spoons.

design Dodo Arslan
terzani.com

TERZANI
LA LUCE PENSATA



Type |
Floor lamp

Materials |
Brass

Finishes | Code

 Nickel
0Q63P E7 C8

 Gold leaf
0Q63P H5 C8

Body |

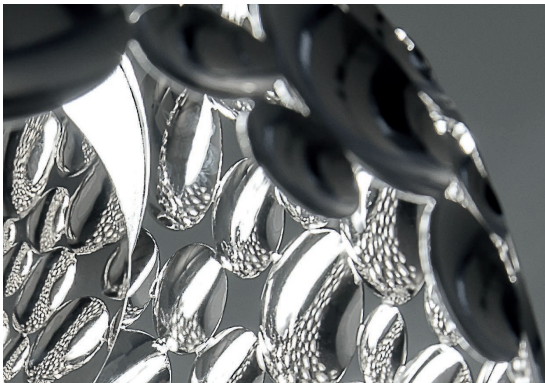
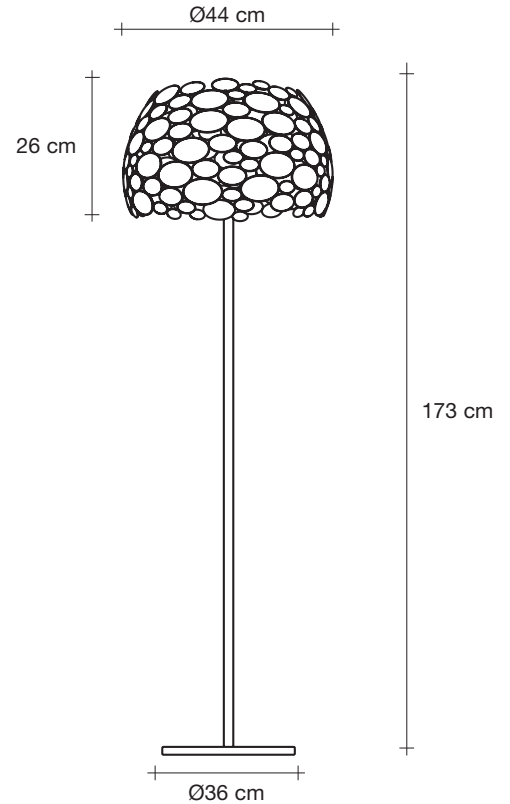

Integrated Led |

230-240V ~ 50/60Hz

 LED integrated
6 x 4,5W 3180 lm 3000K
or optional 2700K

 Not Dimmable

A playful study of reflection, the idea for Anish was born when designer Dodo Arslan, while playing with his daughter, became fascinated by the almost infinite reflections spoons unleashed due to their concave and convex surfaces. Taking this idea to a larger scale, Dodo took inspiration from Italian flatware manufacturer Sambonet and created a pendant composed of a range of spoons from the smallest teaspoon to serving spoons which magnifies the reflective quality of this shape. The result is an installation that creates a "galaxy" effect of seemingly endless light. Design Dodo Arslan.

