

## 10019771 / 10019791

2W LED / 5W Total

incl. LED Board: L9002859

1800 mAh / 3.7 Vdc 18650 Li-ion battery / 5Vdc constant voltage / 1A

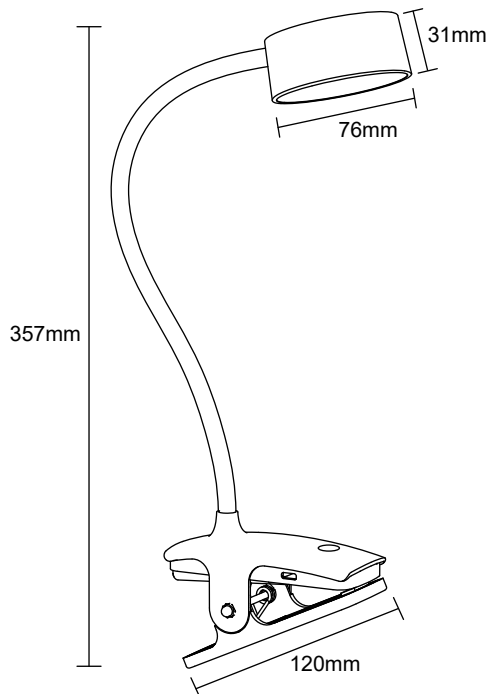





### (DE) Bestimmungsgemäße Verwendung

(EN) Intended use | (FR) Utilisation conforme | (NL) Beoogd gebruik | (PL) Stosowanie zgodnie z przeznaczeniem | (NO) Riktig bruk | (DK) Korrekt brug  
 (SE) Avsedd användning | (FI) Määräystenmukainen käyttö | (IT) Impiego appropriato | (ES) Uso prescrito | (CZ) Použití v souladu s určením  
 (PT) Utilização correta | (GR) Ενδεδειγμένη χρήση | (SK) Predpokladané použitie | (EE) Eeldatav kasutus | (LV) Paredzamais lietojums  
 (LT) Numatomas naudojimas | (RO) Utilizare intenționată | (SI) Predvidena uporaba | (HR) Namjenska upotreba | (HU) Tervezett felhasználás  
 (BG) предназначена употреба | (AL) Përdorimi i parashikuar | (MK) Предвидена употреба | (TR) Amaçlı kullanım | (UK) Призначене використання  
 (BA,ME,RS) Namjenska upotreba

(DE)	Als Klemmleuchte im Innenbereich	(GB)	Provided for use as clip light, indoors
(FR)	En tant que lampe à pince, à l'intérieur	(NL)	Als klemlamp binnenshuis
(PL)	Jako lampa zaciskowa do wnętrz	(NO)	Som klemmelys innendørs
(DK)	Som klemmelys indendørs	(SE)	Används som klämlampa inomhus
(FI)	Käyttö sisätilojen klipsivalaisimena	(IT)	Impiego come lampada con morsetto in ambienti interni
(ES)	Empleo en tanto lámpara de pinza en interiores	(CZ)	Použití jako svorkové svítidlo v interiéru
(PT)	Aplicação como candeeiro de mola em interiores	(GR)	Χρήση ως φωτιστικό με σφιγκτήρα σε εσωτερικό χώρο
(SK)	Ako vnútorné svetlo s klipom	(BG)	Като вътрешна лампа с щипка
(EE)	Sisemise klambri valgusena	(LV)	Kā iekšējā klamja gaisma
(LT)	Kaip vidinis spaustuko šviesa	(RO)	Ca lumină cu clema în interior
(SI)	Kot notranja svetilka s sponko	(HR)	Kao unutarnja svjetiljka s kopčom
(HU)	Benti csipeszes lámpaként	(AL)	I ofruar për përdorim si dritë klip, brenda
(MK)	Обезбедено за користење како клип светло, внатре	(TR)	Klip ışığı olarak kullanım için sağlanmış, iç mekanlar için
(UK)	Забезпечено для використання як світло для затиску, всередині	(BA)	Obezbijeđeno za upotrebu kao svjetlo za pričvršćivanje, unutra
		(ME)	
		(RS)	

<b>(DE) Lieferumfang</b>		
<b>(EN) Package contents   (FR) Contenu de la livraison   (NL) Bij de levering inbegrepen   (PL) Zakres dostawy   (NO) Levering   (DK) Leveringsomfang (SE) Leveransomfatning   (FI) Toimitussisältö   (IT) Fornitura   (ES) Volumen de suministro   (CZ) Rozsah dodávky   (PT) Material fornecido (GR) Περιεχόμενα εξοπλισμού   (SK) Obsah balenia   (EE) Pakendi sisu   (LV) Pakas saturs   (LT) Pakuotės turinys (RO) Conținutul pachetului   (SI) Vsebina paketa   (HR) Sadržaj paketa   (HU) A csomag tartalma   (BG) обхват на доставката (AL) Përmbajtja e dorëzimit   (MK) Содржина на испорака   (TR) Teslimat içeriği   (UK) Зміст доставки   (BA,ME,RS) Sadržaj isporuke</b>		
<b>(DE)</b> 1 Klemmleuchte Montagematerial Montageanleitung	<b>(GB)</b> 1 Clip light Installation hardware Mounting instructions	<b>(FR)</b> 1 Lampe à pince Matériel de montage Instructions de montage
<b>(NL)</b> 1 Klemlamp Monteringsmateriale Montagehandleiding	<b>(PL)</b> 1 Lampa zaciskowa Elementy montażowe Instrukcja montażu	<b>(NO)</b> 1 Klemmelys Monteringsmateriale Brukerveiledning
<b>(DK)</b> 1 Klemmelys Monteringsmateriale Brugervejledning	<b>(SE)</b> 1 Klämlampa Monteringsmaterial Monteringsanvisning	<b>(FI)</b> 1 Klipsivalaisin Asennus materiaali Asennusohjeet
<b>(IT)</b> 1 Lampada con morsetto Materiale di montaggio Istruzioni di montaggio	<b>(ES)</b> 1 Lámpara de pinza Material de montaje Instrucciones de montaje	<b>(CZ)</b> 1 Svorkové svítidlo Materiál pro montáž Návod k montáži
<b>(PT)</b> 1 Candeeiro de mola Material de montagem Instruções de montagem	<b>(GR)</b> 1 Φωτιστικό με σφιγκτήρα Υλικό συναρμολόγησης Οδηγίες συναρμολόγησης	<b>(SK)</b> 1 Klipové svetlo Inštalačný hardvér Inštalačná príručka
<b>(BG)</b> 1 Светлина с щипка материали за монтаж инструкции за монтаж	<b>(EE)</b> 1 Klambri valgus Paigaldustarvikud Paigaldusjuhend	<b>(LV)</b> 1 Klamja gaisma Instalācijas aparatūra Uzstādīšanas instrukcija
<b>(LT)</b> 1 Spraustuko šviesa Montavimo aparatinė įranga Montavimo instrukcija	<b>(RO)</b> 1 Lumină cu clema Hardware de instalare Instrucțiuni de montare	<b>(SI)</b> 1 Svetilka s sponko Namestitvena strojna oprema Navodila za montažo
<b>(HR)</b> 1 Svjetlo s kopčom Instalacijski hardver Upute za montažu	<b>(HU)</b> 1 Csípeszes lámpa Telepítési hardver Szerelési útmutató	<b>(AL)</b> 1 Dritë klipse Materiali i montimit Udhëzuesi i montimit
<b>(MK)</b> 1 Светло со клип Монтажен материјал Упатство за монтажа	<b>(TR)</b> 1 Klips ışık Montaj malzemesi Montaj kılavuzu	<b>(UK)</b> 1 Світло на зажимі Монтажний матеріал Інструкція з монтажу
<b>(BA)</b> 1 Svjetlo sa stezaljkom		
<b>(ME)</b> Montažni materijal		
<b>(RS)</b> Uputstvo za montažu		

<b>(DE) Verwendete Symbole</b>	
<b>(EN) Safety Precautions   (FR) Symboles utilisés   (NL) Gebruikte symbolen   (PL) Stosowane symbole   (NO) Brukte symboler   (DK) Brugte symboler (SE) Använda symboler   (FI) Käytetyt symbolit   (IT) Simboli usati   (ES) Símbolos empleados   (CZ) Použité symboly   (PT) Símbolos utilizados (GR) Χρησιμοποιούμενα σύμβολα   (SK) Bezpečnostné opatrenia   (EE) Ohutusabinõud   (LV) Drošības pasākumi (LT) Saugos priemonės   (RO) Măsuri de precauție   (SI) Varnostni ukrepi   (HR) Mjere opreza   (HU) Használt szimbólumok   (BG) Мерки за безопасност (AL) Simbolet e përdorura   (MK) Користени симболи   (TR) Kullanılan semboller   (UK) Використовувані символи   (BA,ME,RS) Korišteni simboli</b>	
IP 20	   

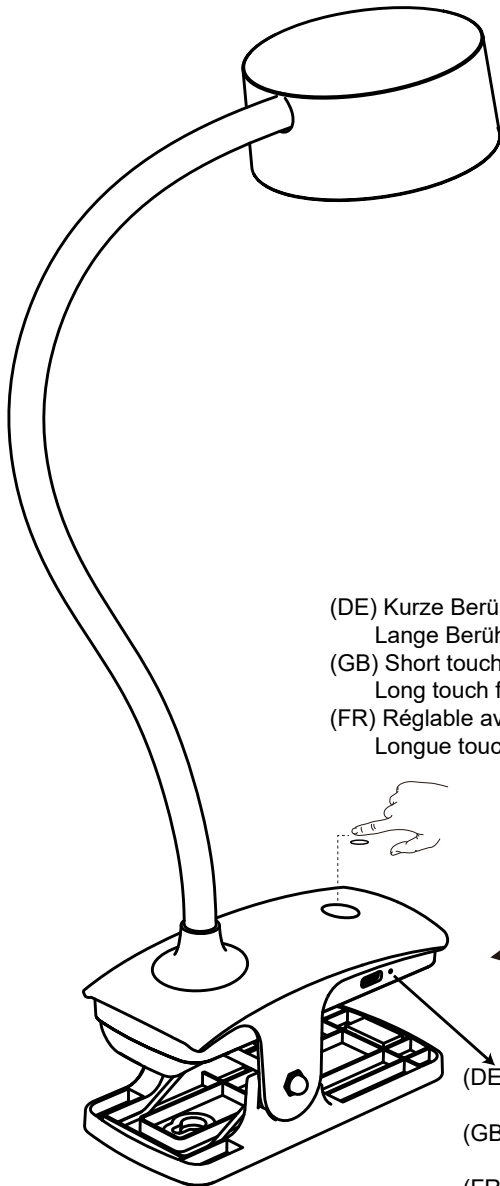

- (DE) Kurze Berührung zum Dimmen, 15%-40%-100%.  
Lange Berührung für CCT, 3000K-6500K, stufenlos.  
(GB) Short touch for dimming, 15%-40%-100%.  
Long touch for CCT, 3000K-6500K, stepless.  
(FR) Réglable avec un toucher court, 15% - 40% - 100%.  
Longue touche CCT, 3000k - 6500k, vitesse variable en continu.

- (DE) Die Kontrollleuchte leuchtet orange, wenn der Akku aufgeladen ist,  
wechselt auf grün, wenn der Akku vollständig aufgeladen ist.  
(GB) Indicator light will be orange when battery is charged,  
will change to green when fully charged.  
(FR) L'indicateur sera orange lorsque la batterie est chargée et deviendra vert  
lorsqu'elle est complètement chargée.

<p>(DE) Dieses Produkt enthält eine Lichtquelle der Energieeffizienzklasse D  (EN) This product contains a light source of energy efficiency class D  (FR) Ce produit comprend une source de lumière de classe d'efficacité énergétique D  (NL) Dit product bevat een lichtbron van energie-efficiëntieklasse D  (PL) Produkt ten zawiera źródło światła o klasie efektywności energetycznej D  (NO) Dette produktet inneholder en lyskilde i energieeffektivitetsklasse D  (DK) Dette produkt indeholder en lyskilde af energieeffektklasse D  (SE) Denna produkt innehåller en ljuskälla i energieffektivitetsklass D  (FI) Tämä tuote sisältää energiatehokkuusluokan D valonlähteen  (IT) Questo prodotto contiene una sorgente luminosa della classe di efficienza energetica D  (ES) Este producto contiene una fuente de luz de la clase de eficiencia energética D  (CZ) Tento výrobek obsahuje světelný zdroj třídy energetické účinnosti D  (PT) Este produto contém uma fonte de luz da classe de eficiência energética D  (GR) Αυτό το προϊόν περιέχει μια φωτεινή πηγή ενεργειακής απόδοσης κλάσης D  (SK) Tento výrobok obsahuje zdroj svetla triedy energetickej efektivity D  (EE) See toode sisaldab energiatõhususklassi D valgusallikat  (LV) Šis produkts satur enerģijas efektivitātes klases D gaismas avotu  (LT) Šis gaminys turi energijos efektyvumo klasės D šviesos šaltinį  (RO) Acest produs conține o sursă de lumină de clasă de eficiență energetică D  (SI) Ta izdelek vsebuje svetlobni vir energijskega razreda D  (HR) Ovaj proizvod sadrži izvor svjetlosti energetske učinkovitosti klase D  (HU) Ez a termék egy D energiatékonysági osztályú fényforrást tartalmaz  (BG) Този продукт съдържа източник на светлина с клас на енергийна ефективност: D  (AL) Ky produkt përmban një burim drite të klasës së efikasitetit të energjisë D  (MK) Овој производ содржи извор на светлина од класа на енергетска ефикасност D  (TR) Bu ürün, enerji verimliliği sınıfı D olan bir ışık kaynağı içerir  (UK) Цей продукт містить джерело світла класу енергоефективності D  (BA)(ME)(RS) Ovaj proizvod sadrži izvor svjetlosti energetske klase D</p>	<p>QR</p> 	<p>EAN</p> <p>4251911782981</p>
--	---	---------------------------------

	<p>(DE) Die Lichtquelle dieser Leuchte ist nicht ersetzbar.  (EN) The light source is not replaceable.  (FR) La source lumineuse de cette lampe n'est pas remplaçable.  (NL) De lichtbron van deze lamp is niet vervangbaar.  (PL) Źródło światła w tej lampie jest niewymienne.  (NO) Lyskilden i denne lampen er ikke mulig å bytte ut.  (DK) Lyskilden til denne lampe kan ikke udskiftes.  (SE) Ljuskällan i denna lampa är inbyggd och är inte utbytbar.  (FI) Tämän valaisimen valonlähde ei voi vaihtaa.  (IT) La sorgente luminosa di questa lampada non è sostituibile.  (ES) La fuente de luz de esta lámpara no es reemplazable.  (CZ) Světelný zdroj nelze vyměnit.  (PT) A fonte de luz deste candeeiro não permite a substituição.  (GR) Η πηγή φωτισμού αυτού του φωτιστικού δεν μπορεί να αντικατασταθεί.  (SK) Svetelný zdroj tohto svetidla nie je vymeniteľný.  (EE) Valgusallikat ei saa asendada.  (LV) Gaismas avots nav aizstājams.  (LT) Šviesos šaltinis nekeičiamas.  (RO) Sursa de lumină nu poate fi înlocuită.  (SI) Vir svetlobe ni zamenljiv.  (HR) Izvor svjetla nije zamjenjiv.  (HU) A fényforrás nem cserélhető ki.  (BG) Източникът на светлина не може да се замени.  (AL) Burimi i dritës nuk mund të zëvendësohet.  (MK) Изворот на светлина не е заменлив.  (TR) Işık kaynağı değiştirilemez.  (UK) Джерело світла не можна замінити.  (BA)(ME)(RS) Izvor svjetlosti nije zamjenjiv.</p>
---	--